

Nexa TOPCon N-type

> 420 - 450W

+23.0%

Module efficiency
Module efficiency up to 23.04 %



Different designs
Black - Silver



PID resistance
Certified according to IEC TS 62804 standards



High reliability
Certified resistance against salt mist, dust, sand, and ammonia



Hail resistance
RG3/HW3 certified



Easy to handle
Comfortable installation thanks to an optimized area size

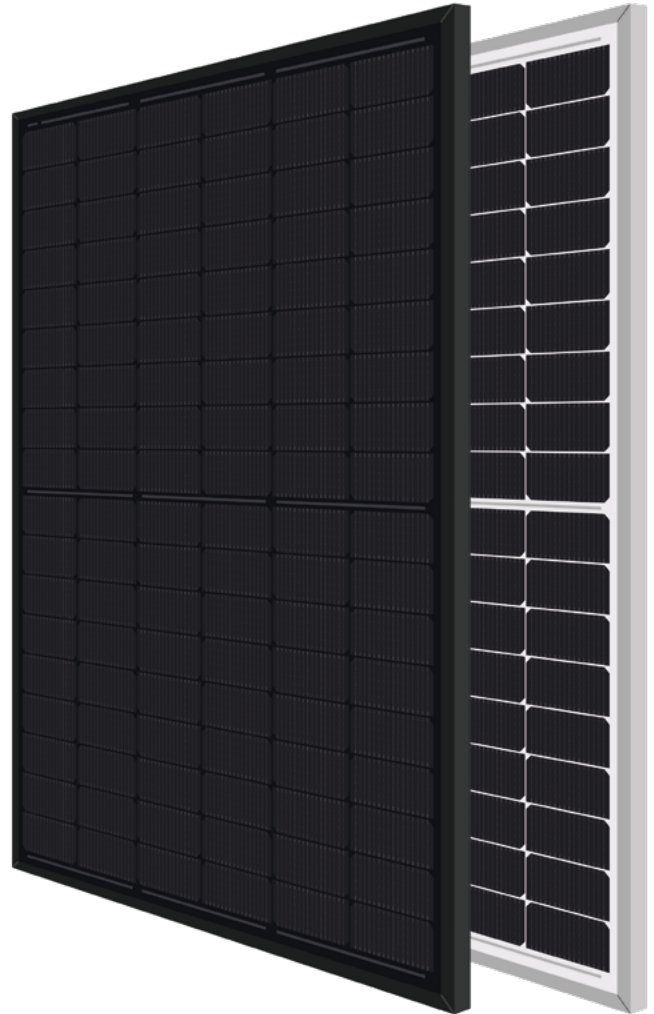

20 Years

Product Warranty
+5 years for Premium Partners

30 Years

Performance Warranty
Linear Warranty

1% First year degradation

0.38% Annual degradation

88% Power in year 30

Light up your world with Eurener

Eurener's extensive portfolio of certifications and awards is testament to our unwavering commitment to our partners and our deep sense of social and ethical responsibility.



Spanish Quality Worldwide



Awarded as TOP Brand PV



EcoVadis Platinum Medal for three consecutive years

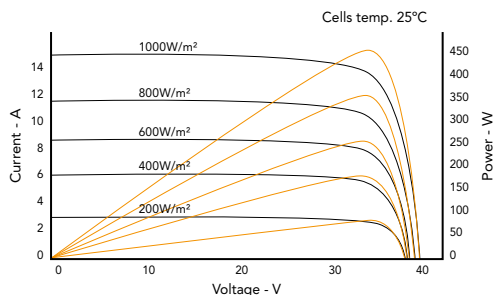
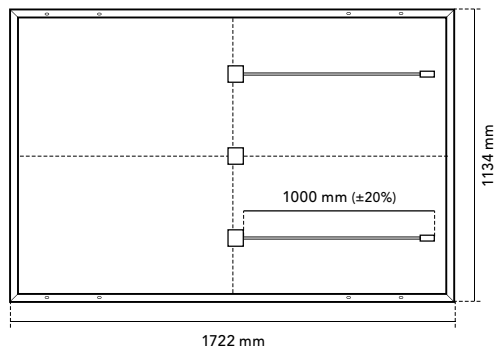

Mechanical specification	
Solar cells	N-Type monocrystalline silicon cells
Front Glass	3.2 mm thick tempered glass with high strength and ARC
Frame	Black/silver anodized aluminium
Junction Box	IP68, 3 by-pass diodes
Connector	Original MC4-Evo 2
Cable	1000 mm (±20%) length and 4 mm ² section
Dimension	1722 x 1134 x 30 mm (±1%)
Area	1.95 m ²
Weight	22 kg
Packaging	962 pcs/truck

Temperature coefficients	
Temperature coefficient of Isc (α)	0.045 %/°C
Temperature coefficient of Voc (β)	-0.275 %/°C
Temperature coefficient of Pmax (γ)	-0.29 %/°C
Temperature range	-40 °C ~ +85 °C
Nominal operating cell temperature (NOCT)	45 ± 2 °C

	MEPV 420	MEPV 425	MEPV 430	MEPV 435	MEPV 440	MEPV 450
Electrical characteristics						
STC						
Nominal power. Pmax	420 Wp	425 Wp	430 Wp	435 Wp	440 Wp	450 Wp
Short-circuit current (Isc)	14.08 A	14.16 A	14.26 A	14.30 A	14.37 A	14.52 A
Open-circuit voltage (Voc)	38.09 V	38.28 V	38.42 V	38.70 V	38.91 V	39.33 V
Maximum power current (Imp)	13.34 A	13.42 A	13.52 A	13.56 A	13.63 A	13.76 A
Maximum power voltage (Vmp)	31.49 V	31.68 V	31.82 V	32.09 V	32.30 V	32.71 V
Module efficiency	21.51 %	21.76 %	22.02 %	22.28 %	22.53 %	23.04 %
Electrical characteristics						
NOCT						
Nominal power. Pmax	322 Wp	325 Wp	329 Wp	333 Wp	337 Wp	345 Wp
Short-circuit current (Isc)	11.34 A	11.41 A	11.47 A	11.54 A	11.61 A	11.75 A
Open-circuit voltage (Voc)	36.52 V	36.70 V	36.88 V	37.06 V	37.24 V	37.61 V
Maximum power current (Imp)	10.75 A	10.81 A	10.88 A	10.94 A	11.01 A	11.14 A
Maximum power voltage (Vmp)	29.92 V	30.10 V	30.27 V	30.45 V	30.63 V	30.99 V

* STC: 1000 W/m², module temperature 25°C, AM 1.5

* NOCT: 800 W/m², ambient temperature 20°C, AM 1.5

Operating parameters	
Maximum voltage	1500 V
Maximum series fuse rating. Ir	30 A
Power output tolerance	0 - +3 %
Voc and Isc tolerance	± 3 %
Fire rating	BROOF (t4) (EN 13501-5)
	Class A or C (UL 790)
Protection class	Class II (IEC 61140)
Mechanical loads	Front load 5400 Pa, Back load 2400 Pa

Corporate and product certificates	
ECOVADIS rating - Platinum Medal (TOP 1%)	
Solar Industry Forced Labor Prevention Pledge by SEIA	
ISO9001:2015 - Quality Management Systems	
ISO14001:2015 - Environmental Management System	
WEEE compliance in Germany	
PV CYCLE Italy	
IEC 61215 - Terrestrial photovoltaic (PV) modules - Design qualification and type approval	
IEC 61730 - Photovoltaic (PV) module safety qualification	
IEC 61701 - Photovoltaic (PV) modules - Salt mist corrosion testing	
IEC 62716 - Photovoltaic (PV) modules - Ammonia corrosion testing	
IEC TS 62804 - Photovoltaic (PV) modules - Test methods for the detection of potential-induced degradation	
Hail resistance HW3/RG3	
Certificate of Factory Production Control (UK) - MCS	
Fire reaction class: 1 - LAPI	
Swissolar Quality Certificate	



NOTE: All information contained in this data sheet is provided for general information purposes only. Product specifications may be subject to technical modifications. Reception, installation and use shall comply with the applicable Installation Manual, General Conditions of Sale and Warranty Terms and Conditions. The latest versions of all technical documentation are available at www.eurener.com.

SINCE
1997
more than
energy

eurener.com
contact@eurenerworld.com
+34 960 045 515
Calle Colón, 1-23
46004, Valencia. Spain

European experts in residential modules

Since 1997 our main purpose has been to supply quality and long-lasting photovoltaic modules that allow us and future generations, to continue generating clean energy to take care of our planet.