



Nexa Storm TOPCon N-type

FRONT SIDE

430 - 450W

› Double Glass Bifacial

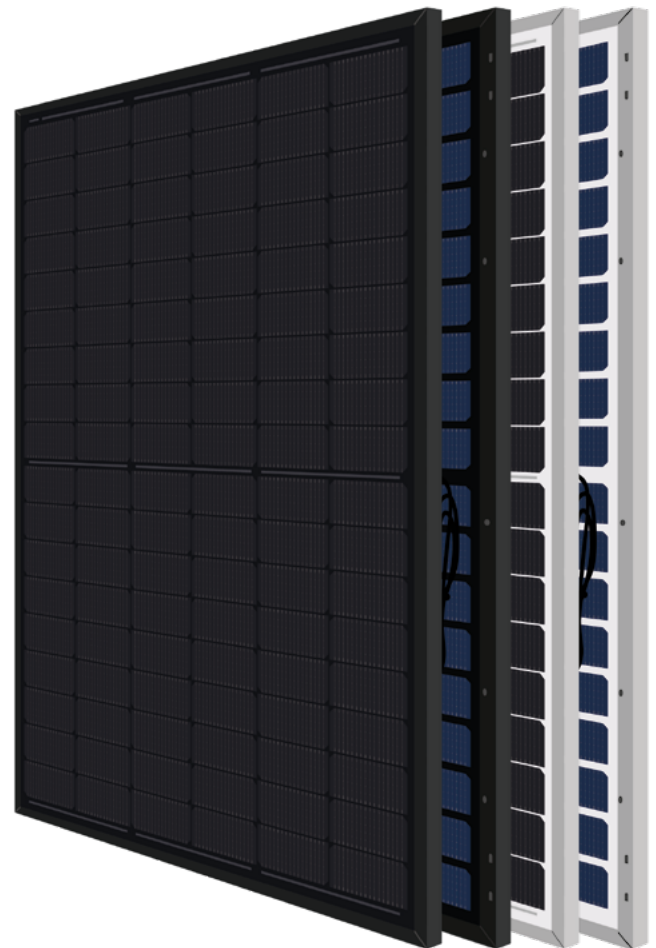

Hail resistance
RG4/HW4 certified



Extreme load resistance
Maximum test load (snow) 15100 Pa



Glass glass modules
Front: 3.2 mm | Back: 2 mm



Module efficiency
Module efficiency up to 23.04 %



Bifacial cell
Bifaciality factor: 80 ± 5 %



Original MC4 - Evo2
Extra security and reliability

25 Years

Product Warranty
+5 years for Premium Partners

30 Years

Performance Warranty
Linear Warranty

1% First year degradation

0.38% Annual degradation

88% Power in year 30

Light up your world with Eurener

Eurener's extensive portfolio of certifications and awards is testament to our unwavering commitment to our partners and our deep sense of social and ethical responsibility.



Spanish Quality Worldwide



Awarded as TOP Brand PV



EcoVadis Platinum Medal for three consecutive years



Eurener MEPV — NEXA STORM Double Glass Bifacial 430-450W

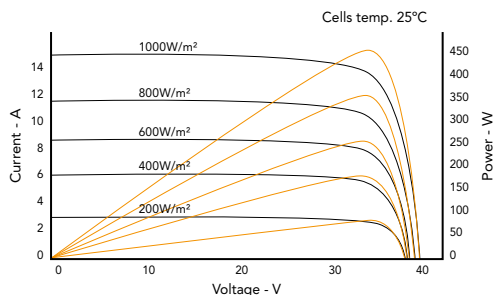
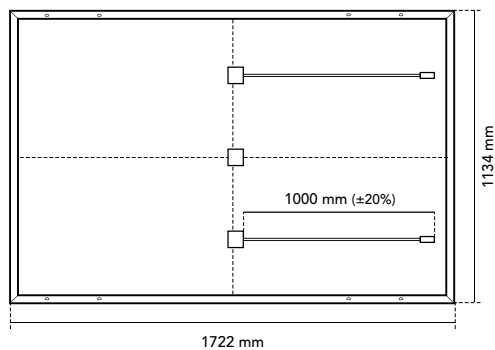

Mechanical specification	
Solar cells	N-Type bifacial monocrystalline silicon cells
Front Glass	3.2 mm anti-reflective surface tempered solar glass
Back Glass	2 mm tempered solar glass
Frame	Black/silver anodized aluminium
Junction Box	IP68, 3 by-pass diodes
Connector	Original MC4-Evo 2
Cable	1000 mm (±20%) length and 4 mm ² section
Dimension	1722 x 1134 x 30 mm (±1%)
Area	1.95 m ²
Weight	27 kg
Packaging	936 pcs/truck

Temperature coefficients	
Temperature coefficient of Isc (α)	0.045 %/°C
Temperature coefficient of Voc (β)	-0.275 %/°C
Temperature coefficient of Pmax (γ)	-0.29 %/°C
Temperature range	-40 °C ~ +85 °C
Nominal operating cell temperature (NOCT)	45 ± 2 °C

	MEPV 430		MEPV 440		MEPV 450	
Electrical characteristics	STC	NOCT	STC	NOCT	STC	NOCT
Nominal power. Pmax	430 Wp	329 Wp	440 Wp	337 Wp	450 Wp	345 Wp
Short-circuit current (Isc)	14.26 A	11.47 A	14.37 A	11.61 A	14.52 A	11.75 A
Open-circuit voltage (Voc)	38.42 V	36.88 V	38.91 V	37.24 V	39.33 V	37.61 V
Maximum power current (Imp)	13.52 A	10.88 A	13.63 A	11.01 A	13.76 A	11.14 A
Maximum power voltage (Vmp)	31.82 V	30.27 V	32.30 V	30.63 V	32.71 V	30.99 V
Module efficiency	22.02 %		22.53 %		23.04 %	

Electrical characteristics	Bifacial gain 10%		
Nominal power. Pmax	473 Wp	484 Wp	495 Wp
Short-circuit current (Isc)	15.63 A	15.81 A	15.97 A
Open-circuit voltage (Voc)	38.49 V	38.91 V	39.33 V
Maximum power current (Imp)	14.82 A	14.99 A	15.13 A
Maximum power voltage (Vmp)	31.91 V	32.30 V	32.71 V

* STC: 1000 W/m², module temperature 25°C, AM 1.5

* NOCT: 800 W/m², ambient temperature 20°C, AM 1.5

Operating parameters	
Maximum voltage	1500 V
Maximum series fuse rating. Ir	25 A
Power output tolerance	0 - + 3 %
Voc and Isc tolerance	± 3 %
Fire rating	BR00F (t4) (EN 13501-5) Class A or C (UL 790)
Protection class	Class II (IEC 61140)
Mechanical loads	Front load 15100 Pa, Back load 3880 Pa

* Laboratory tested according to standard IEC 61215-2:2021 (MQT 16)

Corporate and product certificates	
ECOVADIS rating - Platinum Medal (TOP 1%)	
Solar Industry Forced Labor Prevention Pledge by SEIA	
ISO9001:2015 - Quality Management Systems	
ISO14001:2015 - Environmental Management System	
WEEE compliance in Germany	
PV CYCLE Italy	
IEC 61215 - Terrestrial photovoltaic (PV) modules - Design qualification and type approval	
IEC 61730 - Photovoltaic (PV) module safety qualification	
IEC 61701 - Photovoltaic (PV) modules - Salt mist corrosion testing	
IEC 62716 - Photovoltaic (PV) modules - Ammonia corrosion testing	
IEC TS 62804 - Photovoltaic (PV) modules - Test methods for the detection of potential-induced degradation	
Hail resistance HW3/RG3	
Certificate of Factory Production Control (UK) - MCS	
Fire reaction class: 1 - LAPI	
Assessed by Sundahus	
Swissolar Quality Certificate	



NOTE: All information contained in this data sheet is provided for general information purposes only. Product specifications may be subject to technical modifications. Reception, installation and use shall comply with the applicable Installation Manual, General Conditions of Sale and Warranty Terms and Conditions. The latest versions of all technical documentation are available at www.eurener.com.

SINCE 1997
more than energy

eurener.com
contact@eurenerworld.com
+34 960 045 515
Calle Colón, 1-23
46004, Valencia. Spain

European experts in residential modules

Since 1997 our main purpose has been to supply quality and long-lasting photovoltaic modules that allow us and future generations, to continue generating clean energy to take care of our planet.