



Installation manual

European Experts in Residential Modules »

Contact us › eurener.com

eurener
energía solar



Contents

1. Introduction	⁰³
2. Disclaimer of liability	⁰⁴
3. Safety warnings	⁰⁴
3.1. General	⁰⁴
3.2. Electrical safety	⁰⁴
3.3. Storage and handling	⁰⁴
4. Installation design	⁰⁴
4.1. Environmental conditions	⁰⁴
4.2. Location	⁰⁴
4.3. Orientation and tilt	⁰⁵
5. Electrical installation	⁰⁵
5.1. Series connection	⁰⁵
5.2. Parallel connection	⁰⁵
5.3. Grounding	⁰⁵
6. Mechanical installation	⁰⁶
6.1. Screw mounting	⁰⁶
6.2. Clamp mounting	⁰⁷
7. Cleaning and maintenance	⁰⁸
Annex	⁰⁹

Installation manual

EURENER – PHOTOVOLTAIC MODULES »

1. Introduction

In this manual, the use of the word module (or modules) refers to any PV module from EURENER to be installed or handled.

Standard EURENER modules are composed by the parts shown in Figure 1.

| Figure 1

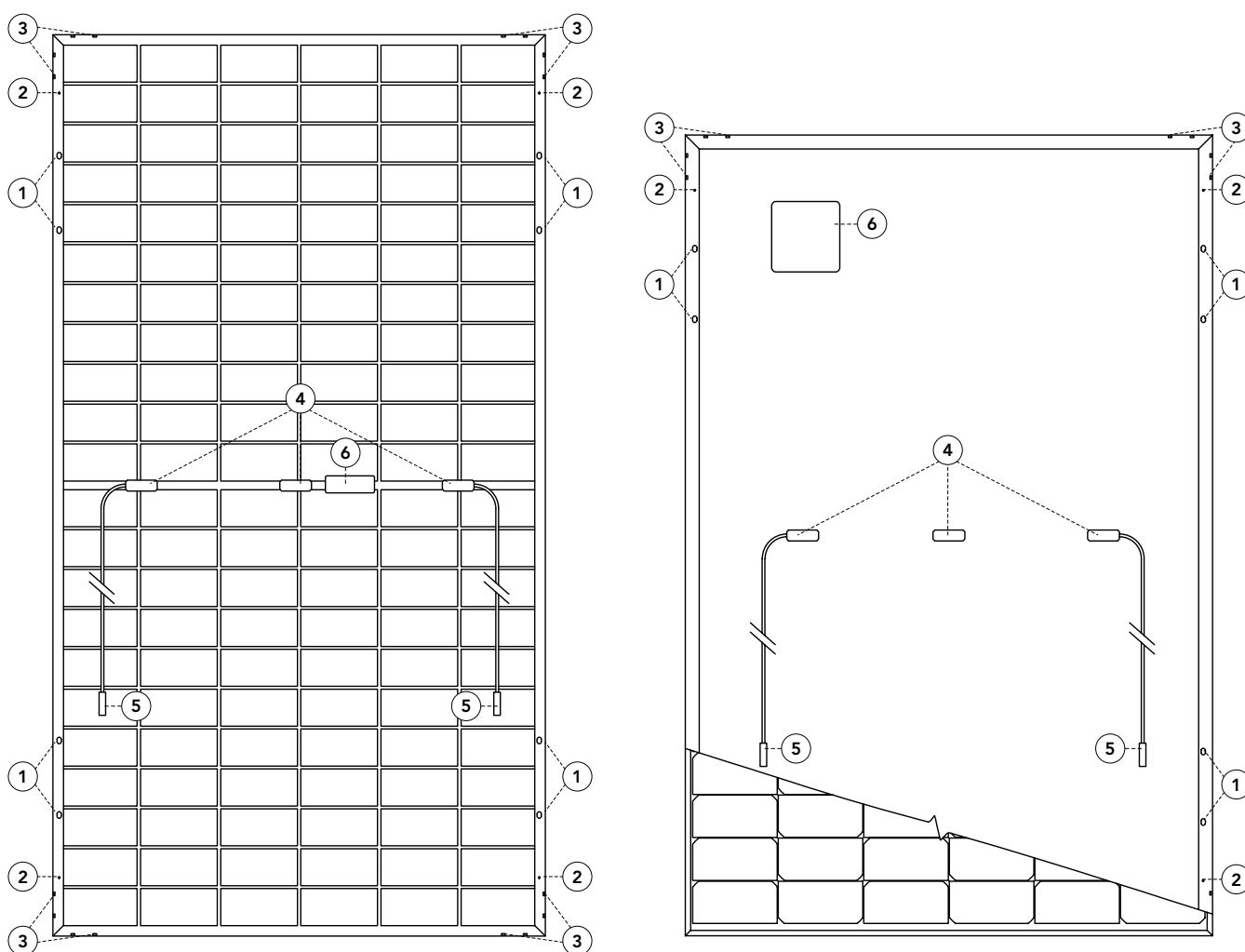

- 1. Mounting holes
- 2. Grounding holes
- 3. Drainage holes
- 4. Junction boxes
- 5. Cables and connectors
- 6. Data label

2. Disclaimer of liability

The use of this manual, the modules or their installation are out of EURENER's scope and control. Therefore, EURENER does not take liability related to loss, damages or costs associated to an improper use, installation or maintenance.

3. Safety warnings

Before handling or installing any EURENER module, all the instructions that appear in this manual should be read and understood in order to prevent harm, material damage or malfunctioning.



3.1. General

- Mechanical and electrical installation must be performed in accordance with all applicable standards and regulations (electrical standards, electrical connection rules, building and security codes). It is recommended to contact the local authorities for specific enquiries in this regard.
- The installation of the modules must be only performed by qualified personnel.
- Appropriate protective equipment must be used during installation (helmet, insulating gloves, safety boots, harnesses... etc.).
- Insulating tools must be used during the installation.
- Modules that show any kind of damage cannot be installed (broken glasses, connectors in bad condition, damaged frames... etc.).
- The modules cannot be modified or disassembled. Any kind of modification on them shall void the warranty.
- The modification or removal of the serial number or data labels shall void the warranty.
- The glass surface must not be scratched with tools nor sharp objects.
- Light should not be concentrated artificially over the module.
- Frame drainage holes should not be covered.
- All the modules installed in the same installation must be of the same type.

3.2. Electrical safety

PV modules are devices that generate electricity, which implies risk of electric shock if the installation and handling are not performed following the suitable security procedures.

- Electrically conducting parts must not be introduced into the connectors or plugs.
- The modules, their cables or their connectors should not be handled with wet hands or without insulated gloves.
- Modules whose cables or connectors are wet, dirty or broken should not be connected.
- During installation, wearing metallic accessories (necklaces, bracelets, rings...etc.) should be avoided.

- Connectors should not be placed near drainage holes nor places that leave them exposed to rain.
- The modules generate electricity when they are exposed to light, so they must be handled with caution, especially their connectors. It is recommended to cover the modules with opaque material during installation.
- Connecting the modules to external elements such as inverters, regulators or battery systems must be carried out with extreme caution. It is recommended to read and follow carefully the instructions given by the manufacturers of these other elements before connecting them.

3.3. Storage and handling

The following recommendations should be followed during storage, transport and handling of the modules:

- Storage temperature: -20°C ~ 50°C.
- The modules should be stored in a clean, ventilated and dry place.
- The modules should be always placed over a surface in vertical position.
- No more than two pallets can be stacked.
- The modules should not be stacked over other modules in horizontal position.
- Handling the modules should be always done with gloves.
- The modules should be held with both hands and not using the cables as handles.
- It is not allowed, under any circumstance, to step on the modules or place objects over their surface.

4. Installation design

4.1. Environmental conditions

- Environment temperature: -40°C ~ 50°C.
- Working temperature: -40°C ~ 85°C.
- Humidity ≤85% RH.
- The load over the module should not exceed 5400Pa (maximum load capacity could vary depending on the mounting system).
- Placing the modules near to highly flammable gasses and vapours should be avoided.
- It is recommended to install the modules at least 500m from the sea to prevent salt mist corrosion.
- Near sulphur sources or volcanoes there is a risk of corrosion.

4.2. Location

- The modules should be placed where they are going to receive the most sunlight during the whole year.
- Caution should be taken with objects near the installation that could cast partial shadows over the modules such as trees, chimneys, antennas, posts, railings or buildings.
- The installation design should allow easy access to all modules during inspection, cleaning or maintenance tasks.

4.3. Orientation and tilt

- To achieve the maximum yearly yield, it is recommended to check previously the appropriate orientation and tilt for the installation's location.
- All the modules from the same string should be installed with the same orientation and tilt.
- The more perpendicular the Sun is to the module, the higher the yield will be.
- It is recommended to install the modules with a minimum tilt of 15° to allow the self-cleaning effect in rain situations.

5. Electrical installation

- The electrical installation must be performed by qualified personnel and following all the standards and security procedures established by local authorities.
- All the modules installed in the same installation must have the same electrical specifications.
- The connection of the connectors should be carried out firmly and securely.
- If open circuit voltage V_{oc} and short-circuit current I_{sc} differ from specifications, perhaps there is a connection failure.
- Creating loops with the cables should be avoided to reduce the risk of indirect lightning strike.
- Cables and connectors should not be subjected to external stress, they should only be used to connect the circuit.
- The cables should not be forced nor bent excessively.
- Cables and connectors should not be exposed directly to sunlight.
- It can only be used cable or connector extensions designed for outdoor applications.
- An appropriate cable diameter should be selected to minimize the voltage drops.
- In order to calculate the minimum cable diameter, the fuse and voltage and current limits of the installation, the V_{oc} and I_{sc} have to be multiplied by a safety factor of 1.25.
- Each connector of the module has a different polarity. The sign of each polarity is represented on the junction boxes.
- Modules can be connected in series, in parallel or mixing both depending on the necessities of the PV system (always considering that maximum voltage and current should not be exceeded).
- The input parameters of the inverter and other components to be used must be taken into account. When electrically designing the installation, the electrical parameter sheets of these items must be consulted prior to installation.

5.1. Series connection

- When connecting various modules in series as shown in Figure 2, the total voltage will be the sum of the voltage given by each module. When connecting the modules in this way, it must be ensured that the maximum system voltage is not exceeded.

- The current will be the same for every module connected in series.

| Figure 2

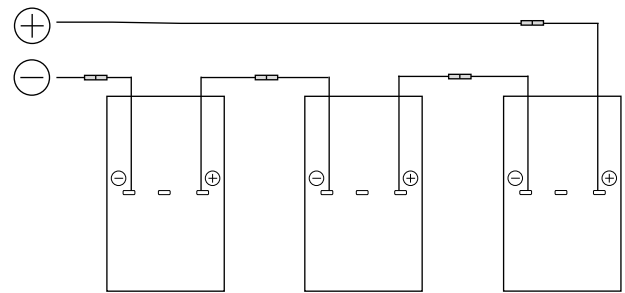

5.2. Parallel connection

- When connecting various modules in parallel as shown in Figure 3, the total current will be the sum of the current given by each module. When connecting the modules in this way, it must be ensured that the maximum system current is not exceeded.
- The voltage will be the same for every module connected in parallel.

| Figure 3

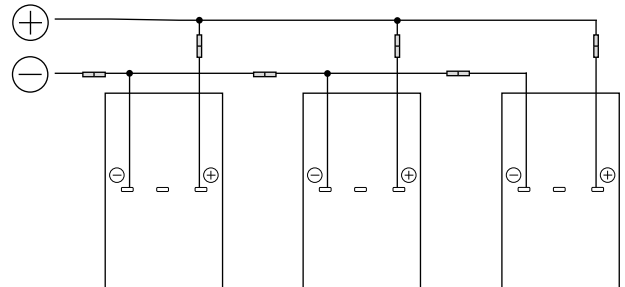

5.3. Grounding

- For safety reasons, the frames of all modules in the installation must be grounded to prevent static and lightning damage.
- The installation of the earthing system must be carried out by qualified personnel and in compliance with regulations and codes established by local authorities.
- Located on the rear side of the modules' frames there are 4mm holes for grounding connection. They can be identified by the symbol \perp .
- It is not allowed to drill additional holes nor modify the frame in any way. Any kind of modification in the modules shall void the warranty.
- All the components used in grounding connection should be of good quality, corrosion resistant and prepared to be outdoors.

- A serrated washer should be used to penetrate the anodized layer of the frame and allow conduction between the frame and the grounding cable.
- A typical scheme of a grounding connection is shown in Figure 4.

| Figure 4

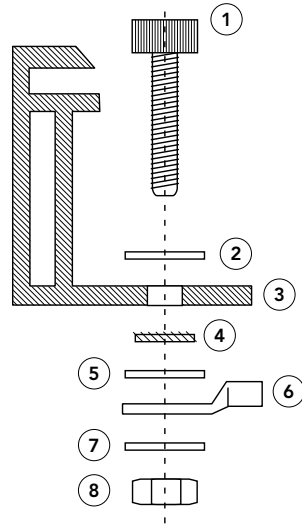

1. M4 Screw
2. Flat washer
3. Frame
4. Serrated washer
5. Flat washer
6. Grounding cable
7. Flat washer
8. Nut

6. Mechanical installation

- EURENER does not provide mounting structures.
- The mounting design must be checked and validated by a professional engineer. The mounting structure system and the carried-out procedures must comply with all the codes and regulations established by the local authorities.
- Standard modules can be installed in structure by different approved methods.
- Dirty or broken modules cannot be installed, they should be checked out before their installation.
- All the components used for mounting should be made from stainless steel (screws, washers, nuts... etc.).
- PV modules are electric devices, so they must be handled and installed by personnel aware of the security procedures.
- The installation of the modules should be carried out by at least two people.
- Special care must be taken not to hit the modules with tools or near objects.
- It is not allowed to drill additional holes nor modify the frame in any way. Any kind of modification in the modules shall void the warranty.

- The modules can be installed in both landscape and portrait position, always following the instructions given by the manufacturer of the mounting system.
- In areas with heavy snowfall (>2400Pa), it is recommended to install additional supporting bars as a reinforcement to the structure.
- In case it is necessary to use an additional supporting bar, it is recommended to choose a resistant material with a minimum thickness of 40mm.
- The minimum distance between modules should be $10\pm 2\text{mm}$ to counteract thermal expansion.
- To guarantee proper ventilation, it is necessary to leave some space between the module and the installation surface.

6.1. Screw mounting

- When installing them to the mounting structure, the modules should be screwed using only the mounting holes located on the rear side of the frame.
- Each module must be installed using at least 4 fixing points, 2 fixing points on each side.
- The other 4 mounting holes of the module should be used in areas where heavy snow and wind loads are expected. The installation designer and the installer have the responsibility of calculating the expected loads at the site and ensure that the mounting structure comply with the requirements.
- For more detailed information, follow the local structural code or contact a professional structural engineer.
- M8 stainless steel screws must be used to fix the frame to the structure.
- A torque wrench must be used to tighten the screws.
- The recommended torque for tightening the screws is 15-20 Nm (unless the manufacturer of the screws or mounting structure gives a different torque value).
- It is mandatory to tighten the screws with suitable torque value, as in case it is less than required there is a risk of low attachment and if it is higher there is a risk of damaging the frame, glass and backsheet.
- Figure 5 shows the typical procedure of screw mounting.
- Annex 1 shows maximum loads in EURENER modules for screw mounting.

| Figure 5

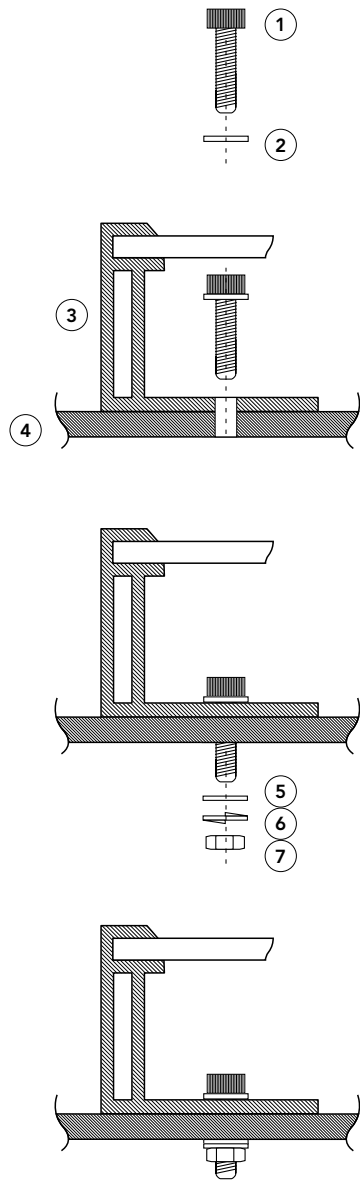

1. M8 screw
2. Flat washer
3. Aluminium frame
4. Mounting structure
5. Flat washer
6. Spring washer
7. Nut

6.2. Clamp mounting

- Each module must be installed using at least 4 fixing points, 2 fixing points on each side.
- In areas where heavy snow and wind loads are expected, additional clamping should be used. The installation designer and the installer have the responsibility of calculating the expected loads at the site and ensure that the mounting structure complies with the requirements.
- For more detailed information, follow the local structural code or contact a professional structural engineer.
- The minimum recommended clamp length is 50mm.
- The clamps should not come into contact with frontal glass. Clamps casting shadows over the module's surface should be avoided.

- Check with the clamp/mounting structure manufacturer the recommended tightening torque for the clamps.
- It is mandatory to tighten the clamps with suitable torque value, as in case it is less than required there is a risk of low attachment and if it is higher there is a risk of damaging the frame, glass and backsheet.
- Figure 6 shows the typical scheme of clamp mounting between modules.
- Figure 7 shows the typical scheme of clamp mounting at the last module position.
- Annex 2 shows maximum loads and recommended clamping areas on EURENER modules for clamp mounting on the short side.
- Annex 3 shows maximum loads and recommended clamping areas on EURENER modules for clamp mounting on the long side.

| Figure 6

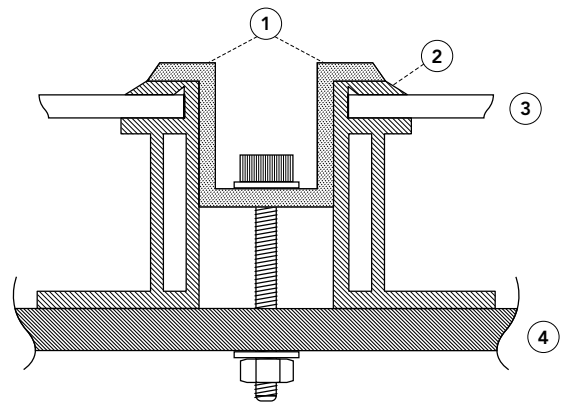

1. Clamp
2. Aluminium frame
3. Glass
4. Mounting structure

| Figure 7

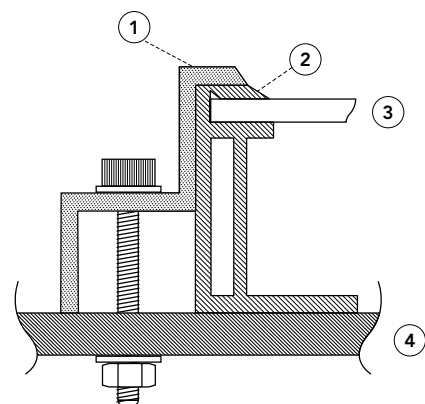

1. Clamp
2. Aluminium frame
3. Glass
4. Mounting structure

7. Cleaning and maintenance

The accumulation of dirt on the surface of the modules can affect their performance and lead to defects such as hot spots. It is recommended to follow the instructions below related to module cleaning:

- It is recommended to install the modules with a minimum tilt of 15° to allow the self-cleaning effect in rain situations.
- It is recommended to perform module cleaning periodically depending on the conditions and circumstances of the installation.
- To clean the surface of the glass, it is advisable to do so at a low temperature, with neutral and low mineralisation water.
- The cleaning should not be carried out with abrasive material as this could damage the glass coating, it is recommended to use a sponge or a soft cloth instead and cleaning all the surface uniformly.
- Soiling should not be dry cleaned as this may cause damage to the glass coating.

It is recommended to carry out the following checks during the maintenance work:

- Presence of broken glass or any kind of damage on the modules.
- Corrosion on the metallization.
- Objects casting shadows over the modules.
- Correct torque values in screws or other fixing elements.
- Check if the cables, connectors and junction boxes are in good condition.
- Electrical connections.

Annex 1: Screw mounting

| Figure 8

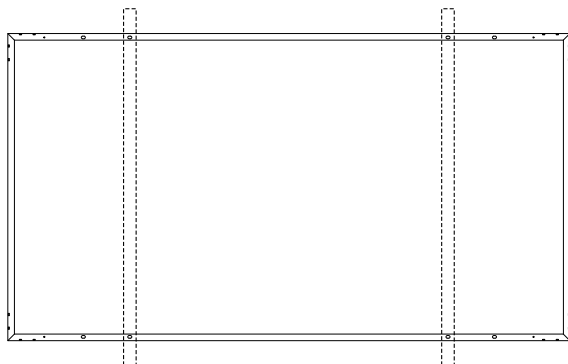

Model	Length (mm)	Width (mm)	Frame (mm)	Test loads (Pa)
MEPV_Nexa_420-450W	1722	1134	30	+5400/-2400
MEPV_Nexa DG Bif_420-450W	1722	1134	30	+5400/-2400
MEPV_Nexa DG Bif_460-475W	1762	1134	30	+5400/-2400
MEPV_Nexa_480-500W	1909	1134	30	+5400/-2400
MEPV_Nexa DG Bif_480-500W	1909	1134	30	+5400/-2400
MEPV_Nexa Plus_570-580W	2278	1134	30/35	+5400/-2400
MEPV_Nexa Plus DG Bif_690-700W	2384	1303	35	+5400/-2400
MEPV_Ultra_400W	1727	1039	30	+5400/-2400
MEPV_Ultra_440W	1895	1039	30	+5400/-2400
MEPV_Ultra DG Bif_440-450W	1895	1039	30	+5400/-2400
MEPV_Icon_340W	1684	1002	35	+5400/-2400
MEPV_Icon_375-380W	1755	1038	35	+5400/-2400
MEPV_Icon_400-420W	1724	1134	30	+5400/-2400
MEPV_Icon Plus_450-460W	2094	1038	35	+5400/-2400
MEPV_Icon Plus_500W	2094	1134	30/35	+5400/-2400
MEPV_Icon Plus_550W	2279	1134	35	+5400/-2400
MEPV_Icon Plus DG Bif_550W	2279	1134	35	+5400/-2400
MEPV_Agro DG Bif_260-275W	1716	1128	-	+5400/-2400
MEPV_Agro DG Bif_325-335W	2094	1134	-	+5400/-2400
MEPV_Agro DG Bif_345-365W	2272	1128	-	+5400/-2400
MEPV_Coloured_350-365W	1722	1134	30	+5400/-2400
MEPV_Terracotta_360-375W	1722	1134	30	+5400/-2400

Annex 2: Clamp mounting – Short side

| Figure 9

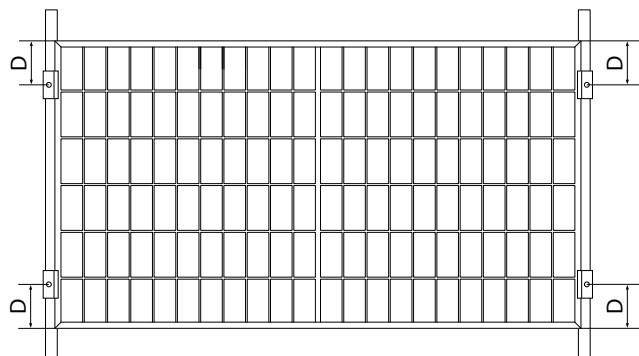

Model	Length (mm)	Width (mm)	Frame (mm)	D (mm)	Test loads (Pa)
MEPV_Nexa_420-450W	1722	1134	30	0 - 200	+2200/-2200
				200 - 250	+2400/-2400
MEPV_Nexa DG Bif_420-450W	1722	1134	30	0 - 200	+2200/-2200
				200 - 250	+2400/-2400
MEPV_Nexa DG Bif_460-475W	1762	1134	30	0 - 200	+2200/-2200
				200 - 250	+2200/-2200
MEPV_Nexa_480-500W	1909	1134	30	0 - 200	+1200/-1200
				200 - 250	+1400/-1400
MEPV_Nexa DG Bif_480-500W	1909	1134	30	0 - 200	+1200/-1200
				200 - 250	+1400/-1400
MEPV_Nexa Plus_570-580W	2278	1134	30/35	-	-
MEPV_Nexa Plus DG Bif_690-700W	2384	1303	35	-	-
MEPV_Ultra_400W	1727	1039	30	0 - 200	+2200/-2200
				200 - 250	+2400/-2400
MEPV_Ultra_440W	1895	1039	30	0 - 200	+2200/-2200
				200 - 250	+2200/-2200
MEPV_Ultra DG Bif_440-450W	1895	1039	30	0 - 200	+2200/-2200
				200 - 250	+2200/-2200
MEPV_Icon_340W	1684	1002	35	0 - 200	+2200/-2200
				200 - 250	+2400/-2400
MEPV_Icon_375-380W	1755	1038	35	0 - 200	+2200/-2200
				200 - 250	+2400/-2400
MEPV_Icon_400-420W	1724	1134	30	0 - 200	+2200/-2200
				200 - 250	+2400/-2400
MEPV_Icon Plus_450-460W	2094	1038	35	0 - 200	+1200/-1200
				200 - 250	+1400/-1400
MEPV_Icon Plus_500W	2094	1134	30/35	-	-
MEPV_Icon Plus_550W	2279	1134	35	-	-
MEPV_Icon Plus DG Bif_550W	2279	1134	35	-	-
MEPV_Agro DG Bif_260-275W	1716	1128	-	0 - 200	+2200/-2200
				200 - 250	+2400/-2400
MEPV_Agro DG Bif_325-335W	2094	1134	-	-	-
MEPV_Agro DG Bif_345-365W	2272	1128	-	-	-
MEPV_Coloured_350-365W	1722	1134	30	0 - 200	+2200/-2200
				200 - 250	+2400/-2400
MEPV_Terracotta_360-375W	1722	1134	30	0 - 200	+2200/-2200
				200 - 250	+2400/-2400

Annex 3: Clamp mounting – Long side

| Figure 10

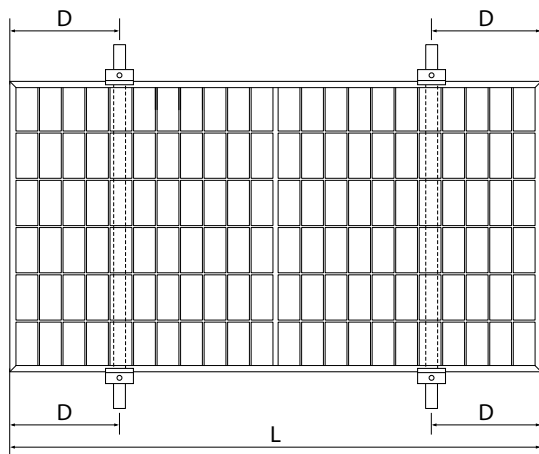

Model	Length (mm)	Width (mm)	Frame (mm)	D (mm)	Test loads (Pa)
MEPV_Nexa_420-450W	1722	1134	30	1/4L - 1/5L	+5400/-2400
MEPV_Nexa DG Bif_420-450W	1722	1134	30	1/4L - 1/5L	+5400/-2400
MEPV_Nexa DG Bif_460-475W	1762	1134	30	1/4L - 1/5L	+5400/-2400
MEPV_Nexa_480-500W	1909	1134	30	1/4L - 1/5L	+5400/-2400
MEPV_Nexa DG Bif_480-500W	1909	1134	30	1/4L - 1/5L	+5400/-2400
MEPV_Nexa Plus_570-580W	2278	1134	30/35	1/4L - 1/5L	+5400/-2400
MEPV_Nexa Plus DG Bif_690-700W	2384	1303	35	1/4L - 1/5L	+5400/-2400
MEPV_Ultra_400W	1727	1039	30	1/4L - 1/5L	+5400/-2400
MEPV_Ultra_440W	1895	1039	30	1/4L - 1/5L	+5400/-2400
MEPV_Ultra DG Bif_440-450W	1895	1039	30	1/4L - 1/5L	+5400/-2400
MEPV_Icon_340W	1684	1002	35	1/4L - 1/5L	+5400/-2400
MEPV_Icon_375-380W	1755	1038	35	1/4L - 1/5L	+5400/-2400
MEPV_Icon_400-420W	1724	1134	30	1/4L - 1/5L	+5400/-2400
MEPV_Icon Plus_450-460W	2094	1038	35	1/4L - 1/5L	+5400/-2400
MEPV_Icon Plus_500W	2094	1134	30/35	1/4L - 1/5L	+5400/-2400
MEPV_Icon Plus_550W	2279	1134	35	1/4L - 1/5L	+5400/-2400
MEPV_Icon Plus DG Bif_550W	2279	1134	35	1/4L - 1/5L	+5400/-2400
MEPV_Agro DG Bif_260-275W	1716	1128	-	1/4L - 1/5L	+5400/-2400
MEPV_Agro DG Bif_325-335W	2094	1134	-	1/4L - 1/5L	+5400/-2400
MEPV_Agro DG Bif_345-365W	2272	1128	-	1/4L - 1/5L	+5400/-2400
MEPV_Coloured_350-365W	1722	1134	30	1/4L - 1/5L	+5400/-2400
MEPV_Terracotta_360-375W	1722	1134	30	1/4L - 1/5L	+5400/-2400



SINCE
1997
more than
energy



eurener.com
contact@eurenerworld.com
+34 960 045 515
Calle Colón, 1-23
46004, Valencia. Spain

European Experts in Residential modules

Since 1997 our main purpose has been to supply quality and long-lasting photovoltaic modules that allow us and future generations, to continue generating clean energy to take care of our planet.
