



PRODUCT CATALOGUE

2024



## European Experts in residential modules

*With over 27 years of experience in photovoltaic panel manufacturing, we work hard to provide our customers with the most durable, efficient, and aesthetically pleasing panels, focusing our efforts on the European residential market.*



SINCE  
1997  
more than  
energy 

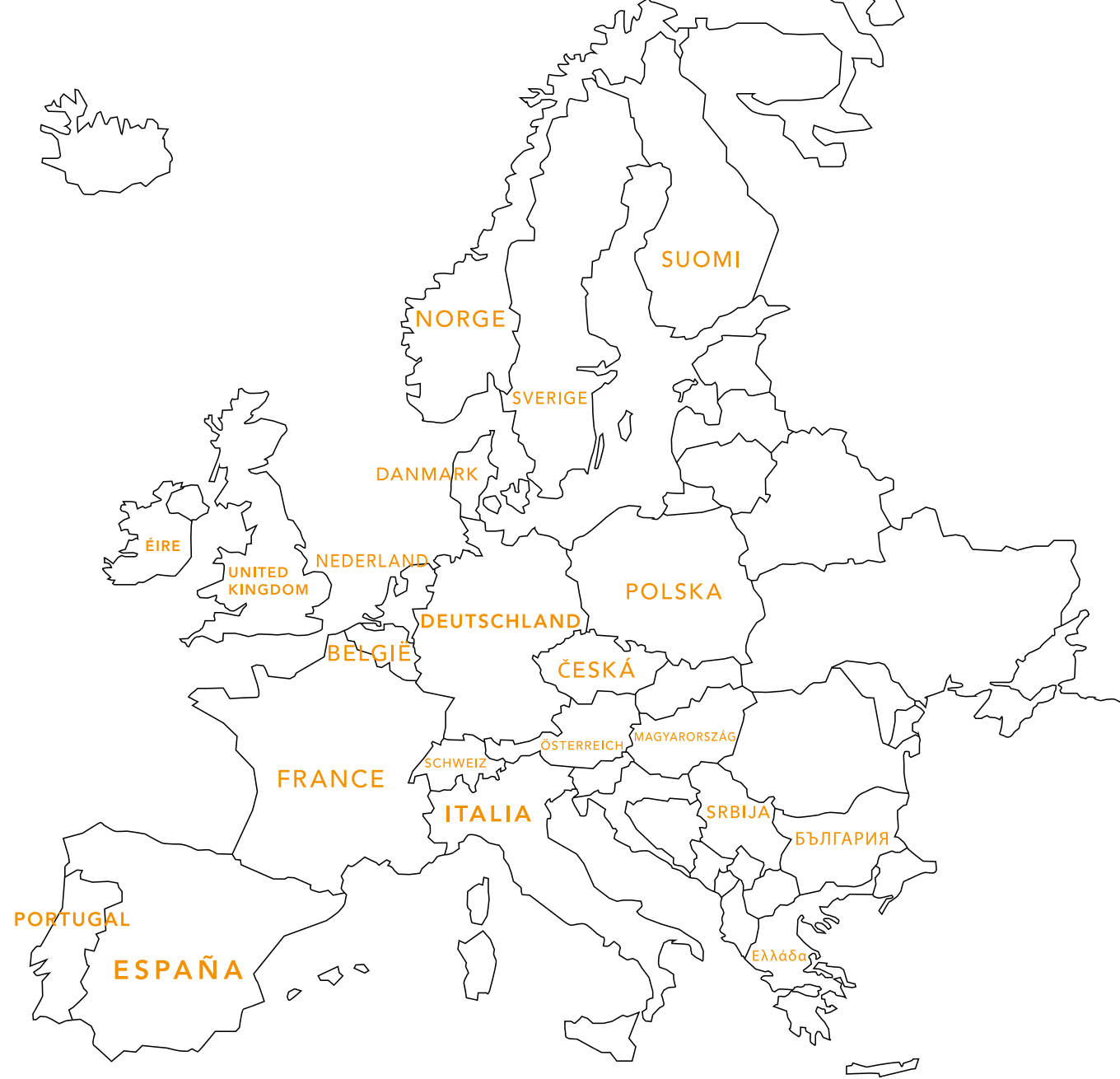

## MANUFACTURING A BETTER WORLD

Our headquarters.  
From Valencia, Spain  
& Eurener Italia in Bergamo.

*Because we want to democratise energy  
and empower people to produce their  
electricity independently, ethically, and  
sustainably, we manage the production  
and distribution of aesthetic, durable, and  
environmentally friendly solar panels.*



Murcia, SPAIN  
Floating solar for self-consumption



# European Experts in residential modules

**6 / 7**

**EURENER**

About us

**12 / 26**

**MEPV NEXA SERIES**

**8 / 9**

**MEPV SERIES  
PRODUCT  
RANGE**

Which Eurener module is the  
most suitable for your project?

**28 / 38**

**MEPV ULTRA SERIES**

**40 / 56**

**MEPV ICON SERIES**

**58 / 66**

**MEPV AGRO SERIES**

**68 / 74**

**MEPV COLOURED SERIES**

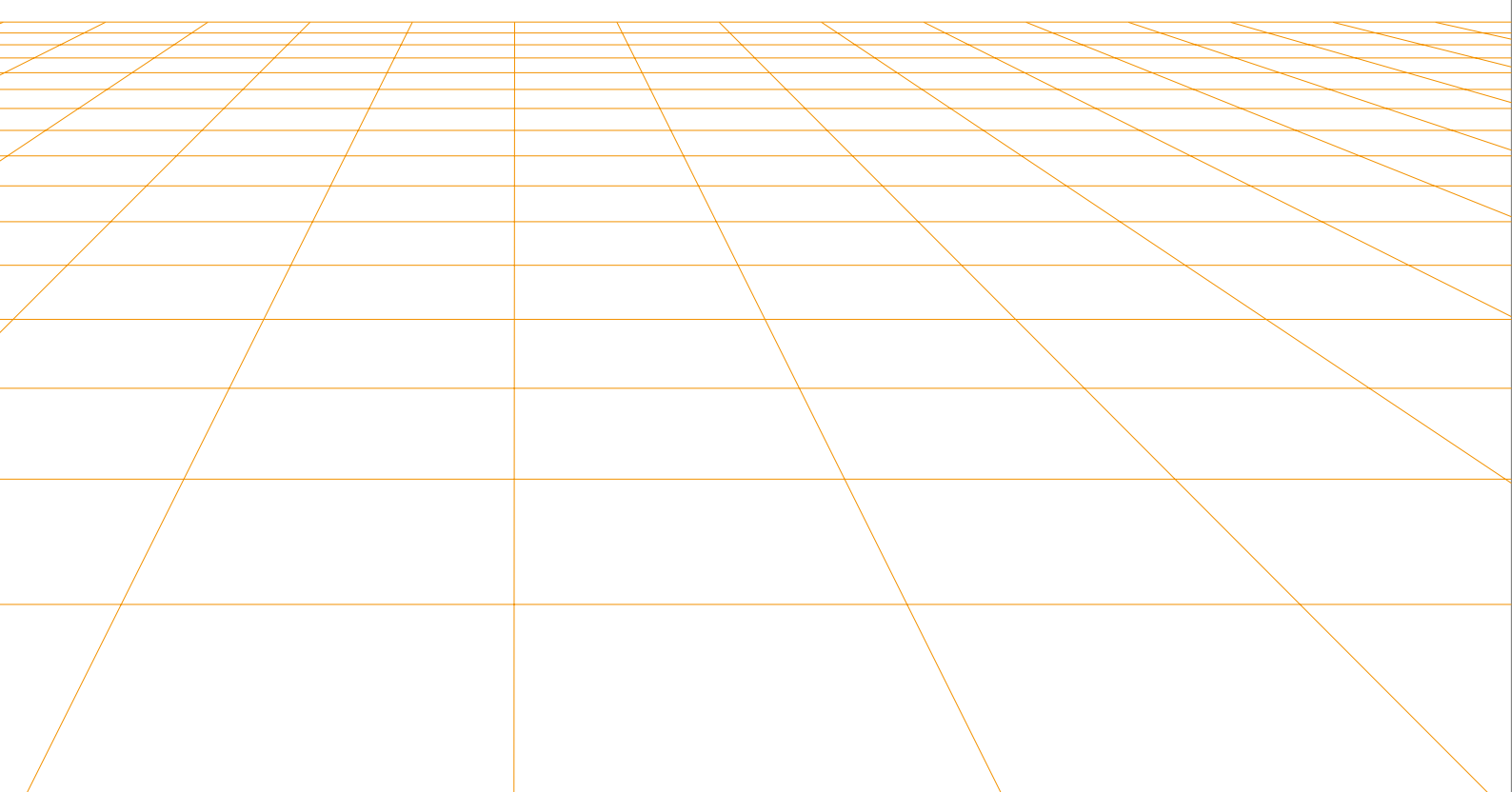



# More Than Energy



**Photovoltaic manufacturers**  
Know how since 1997



**From Spain**  
European quality worldwide



**Up to 30 years warranties**  
The best technology, designed to last



**Two-way communication**  
Personal relationships with our partners

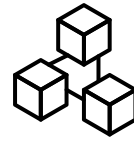

**Unlimited logistics**  
Delivering quality and experience

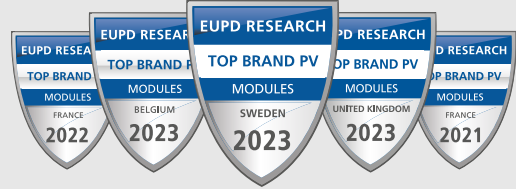

Eurener is a manufacturer of photovoltaic solar modules specialising in European residential designs. We develop products that prioritise high efficiency and architectural integration in solar installations through premium aesthetics. European Installers rank Eurener modules as "TOP BRAND" by EUPD research.



Platinum Medal by EcoVadis for our sustainability, good labour practices, and business ethics. This award places Eurener in the select group of the top 1% of the most sustainable companies in the world.

Headquartered in Valencia, with more than 27 years of experience and production lines in Spain, we have sales offices in Bergamo and logistic warehouses in several European countries, providing excellent service to our partners worldwide.



Eurener modules are installed in more than 50 countries on all five continents. Specialised in residential, we also manufacture photovoltaic modules suitable for industrial and commercial roofs as well as solar parks. We add more than 3,000MW of solar module capacity in tens of thousands of installations for families, sports complexes, educational centres, public administrations, companies and agricultural uses.

Certificates and recognitions confirm Eurener as a manufacturer that works in detail for its partners, with professionalism and a high degree of social and ethical commitment as attested by regular evaluations that consider the environmental impact of manufacturing, sustainable traceability of components, good labour practices and strict respect for human rights throughout the group's value chain.



The highest credit rating, guarantees of up to 30 years on our photovoltaic modules and a proven performance since 1997 make the Eurener Group a reliable partner.

**SINCE 1997**  
more than energy 

## ↘ Capture the sun's energy with our MEPV Series

Our wide range of products, together with the ability to produce ad hoc modules and the know-how gained from many years of experience, results in a reliable and robust product with a high-quality finishing and long-term performance.

### MEPV NEXA SERIES

from 420 to 700Wp

pag. 12/26



- / **25 YEARS**  
PRODUCT WARRANTY  
FOR NEXA DG BIF  
**+5 years** for Premium Partners
- / **20 YEARS**  
PRODUCT WARRANTY  
FOR NEXA AND NEXA PLUS  
**+5 years** for Premium Partners
- / **30 YEARS**  
PERFORMANCE WARRANTY

### MEPV ULTRA SERIES

from 400 to 460Wp

pag. 28/38



- / **25 YEARS**  
PRODUCT WARRANTY  
FOR ULTRA DG  
**+5 years** for Premium Partners
- / **20 YEARS**  
PRODUCT WARRANTY  
FOR ULTRA  
**+5 years** for Premium Partners
- / **30 YEARS**  
PERFORMANCE WARRANTY

## ↘ Reliability and innovation for your projects

Eurener photovoltaic modules have become one of the most efficient and versatile options in the market. We work with technologies that adapt to residential, commercial, and ground-mounted installations.

### MEPV ICON SERIES

from 340 to 550Wp

pag. 40/56



- / **25 YEARS**  
PRODUCT WARRANTY  
FOR ICON DG BIF  
**+5 years** for Premium Partners
- / **20 YEARS**  
PRODUCT WARRANTY  
FOR ICON AND ICON PLUS  
**+5 years** for Premium Partners
- / **30 YEARS**  
PERFORMANCE WARRANTY

### MEPV AGRO SERIES

from 260 to 365Wp

pag. 58/66

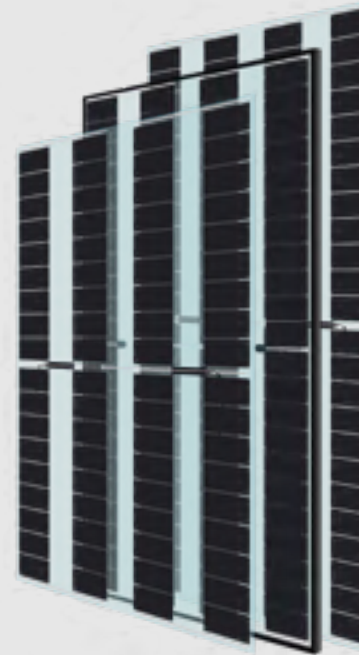

- / **25 YEARS**  
PRODUCT WARRANTY  
**+5 years** for Premium Partners
- / **30 YEARS**  
PERFORMANCE WARRANTY

### MEPV COLOURED SERIES

from 350 to 365Wp

pag. 68/74



- / **20 YEARS**  
PRODUCT WARRANTY  
**+5 years** for Premium Partners
- / **30 YEARS**  
PERFORMANCE WARRANTY



EURENER MODULES

Quality, durability  
and versatility

---





## MEPV NEXA Series

↳ *The next level of solar*

The perfect fusion of the latest technologies in a versatile panel, ideal for different types of solar installations. Exceptional warranties and a premium finishing that redefines excellence in solar energy.

## NEXA — TOPCON N-TYPE TECHNOLOGY

› *from 420 to 700W*



### TOPCon technology

It adds a thin oxide layer to the cell composition to further reduce recombination losses and increase the efficiency.



### N-type cell

Due to their composition, offer higher performance and efficiency than P-type cells and reduce the LID and LeTID effects.



### Lower temperature impact

Modules with better temperature coefficient that reduces thermal losses and improves efficiency in hot climates.



### Project versatility

Modules that fit residential, industrial and large installations thanks to the different available sizes.



### Modules available in double glass with bifacial cells version

More sustainable and reliable modules.

Extra energy yield possibility, thanks to the rear side production of the bifacial cells depending on albedo.



### Original MC4 - Evo2

Modules manufactured with original MC4-EVO 2 connectors by default, adding extra security and reliability to the PV system.

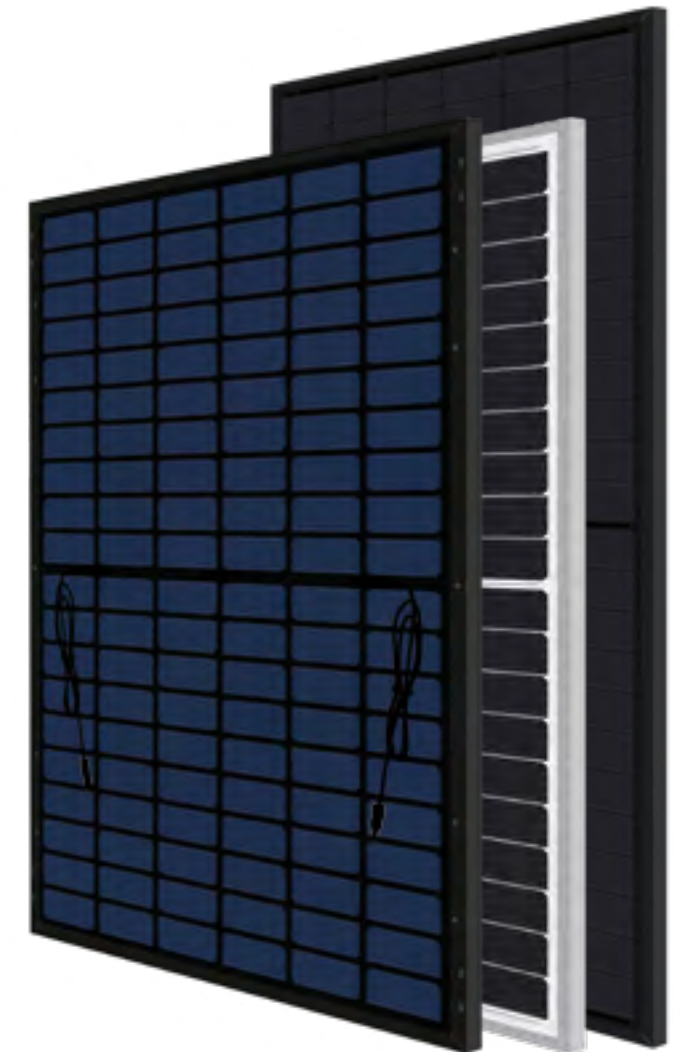



## MEPV Nexa Series

### DATA SHEETS

- › Eurener MEPV Nexa 420-440W  
*pag. 15/16*
- › Eurener MEPV Nexa DG Bif 420-440W  
*pag. 17/18*
- › Eurener MEPV Nexa 480-500W  
*pag. 19/20*
- › Eurener MEPV Nexa DG Bif 480-500W  
*pag. 21/22*
- › Eurener MEPV Nexa Plus 570-580W  
*pag. 23/24*
- › Eurener MEPV Nexa Plus DG Bif 690-700W  
*pag. 25/26*



European Experts  
in Residential Modules

## Nexa TOPCon N-type

# › 420 - 440W



### Module efficiency

Module efficiency up to 22.52 %



### Different designs

Black - Silver



### PID resistance

Certified according to IEC TS 62804 standards



### Increased resistance

Certified resistance against salt mist and ammonia



### Hail resistance

RG3/HW3 certified



### Easy to handle

Comfortable installation thanks to an optimized area size

**20** Years

Product Warranty

+5 years for Premium Partners

**30** Years

Performance Warranty

Linear Warranty

**1%** First year degradation

**0.38%** Annual degradation

**88%** Power in year 30

### Light up your world with Eurener

Eurener's extensive portfolio of certifications and awards is testament to our unwavering commitment to our partners and our deep sense of social and ethical responsibility.





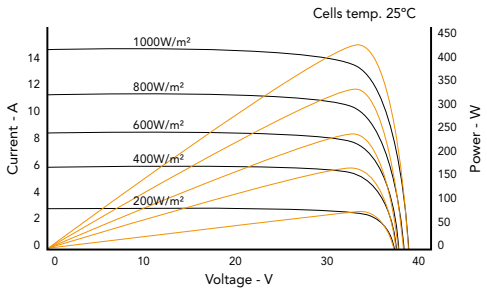
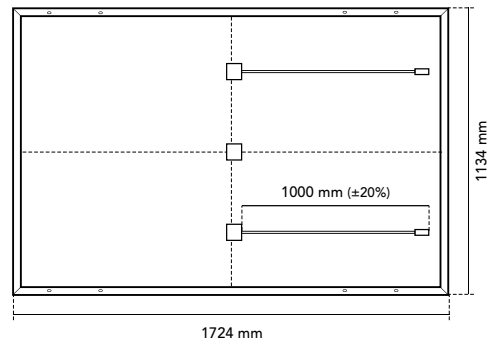

Mechanical Specification	
Solar cells	N-Type monocrystalline silicon cells
Front Glass	3.2 mm thick tempered glass with high strength and ARC
Frame	Black/silver anodized aluminium
Junction Box	IP68, 3 by-pass diodes
Connector	Original MC4-Evo 2
Cable	1000 mm (±20%) length and 4 mm² section
Dimension	1724 x 1134 x 30 mm (±1%)
Area	1.96 m²
Weight	22 kg
Packaging	962 pcs/truck

Temperature Coefficients	
Temperature coefficient of Isc (α)	0.045 %/°C
Temperature coefficient of Voc (β)	-0.275 %/°C
Temperature coefficient of Pmax (γ)	-0.29 %/°C
Temperature range	-40 °C ~ +85 °C
Nominal operating cell temperature (NOCT)	45 ± 2 °C

	MEPV 420	MEPV 425	MEPV 430	MEPV 435	MEPV 440
<b>Electrical Characteristics</b>					
STC					
Nominal power. Pmax	420 Wp	425 Wp	430 Wp	435 Wp	440 Wp
Short-circuit current (Isc)	14.08 A	14.16 A	14.26 A	14.30 A	14.37 A
Open-circuit voltage (Voc)	38.09 V	38.28 V	38.42 V	38.70 V	38.91 V
Maximum power current (Imp)	13.34 A	13.42 A	13.52 A	13.56 A	13.63 A
Maximum power voltage (Vmp)	31.49 V	31.68 V	31.82 V	32.09 V	32.30 V
Module efficiency	21.49 %	21.75 %	22.01 %	22.26 %	22.52 %
<b>Electrical Characteristics</b>					
NOCT					
Nominal power. Pmax	322 Wp	325 Wp	329 Wp	333 Wp	337 Wp
Short-circuit current (Isc)	11.34 A	11.41 A	11.47 A	11.54 A	11.61 A
Open-circuit voltage (Voc)	36.52 V	36.70 V	36.88 V	37.06 V	37.24 V
Maximum power current (Imp)	10.75 A	10.81 A	10.88 A	10.94 A	11.01 A
Maximum power voltage (Vmp)	29.92 V	30.10 V	30.27 V	30.45 V	30.63 V

\* STC: 1000 W/m², module temperature 25°C, AM 1.5  
 \* NOCT: 800 W/m², ambient temperature 20°C, AM 1.5

Operating parameters	
Maximum voltage	1000 - 1500 V
Maximum series fuse rating. Ir	25 A
Power output tolerance	0 - +3%
Voc and Isc tolerance	±3%
Fire rating	Class C (UL 790)
Protection class	Class II (IEC 61140)
Mechanical loads	Front load 5400 Pa, Back load 2400 Pa

Corporate and product certificates	
ECOVADIS rating - Platinum medal (TOP 1%)	
Solar Industry Forced Labor Prevention Pledge by SEIA	
ISO9001:2015 - Quality Management Systems	
ISO14001:2015 - Environmental Management System	
WEEE compliance in Germany	
PV CYCLE Italy	
IEC 61215 - Terrestrial photovoltaic (PV) modules - Design qualification and type approval	
IEC 61730 - Photovoltaic (PV) module safety qualification	
IEC 61701 - Photovoltaic (PV) modules - Salt mist corrosion testing	
IEC 62716 - Photovoltaic (PV) modules - Ammonia corrosion testing	
IEC TS 62804 - Photovoltaic (PV) modules - Test methods for the detection of potential-induced degradation	
Hail resistance HW3/RG3	
Certificate of Factory Production Control (UK) - MCS	
Fire reaction class: 1 - LAPI	



NOTE: Read the safety and installation manual before using the product. This data sheet is not legally binding, Eurener reserves the right of final interpretation. Eurener reserves the right to change the product characteristics and/or specifications without prior notice. The latest versions of all documents can always be found on our website at [www.eurener.com](http://www.eurener.com).

**SINCE 1997**  
 more than energy

**eurener.com**  
 contact@eurenerworld.com  
 +34 960 045 515  
 Calle Colón, 1-23  
 46004, Valencia, Spain

**European Experts in Residential modules**

Since 1997 our main purpose has been to supply quality and long-lasting photovoltaic modules that allow us and future generations, to continue generating clean energy to take care of our planet.

**Nexa TOPCon N-type**

FRONT SIDE  
**420 - 440W**

› Double Glass Bifacial

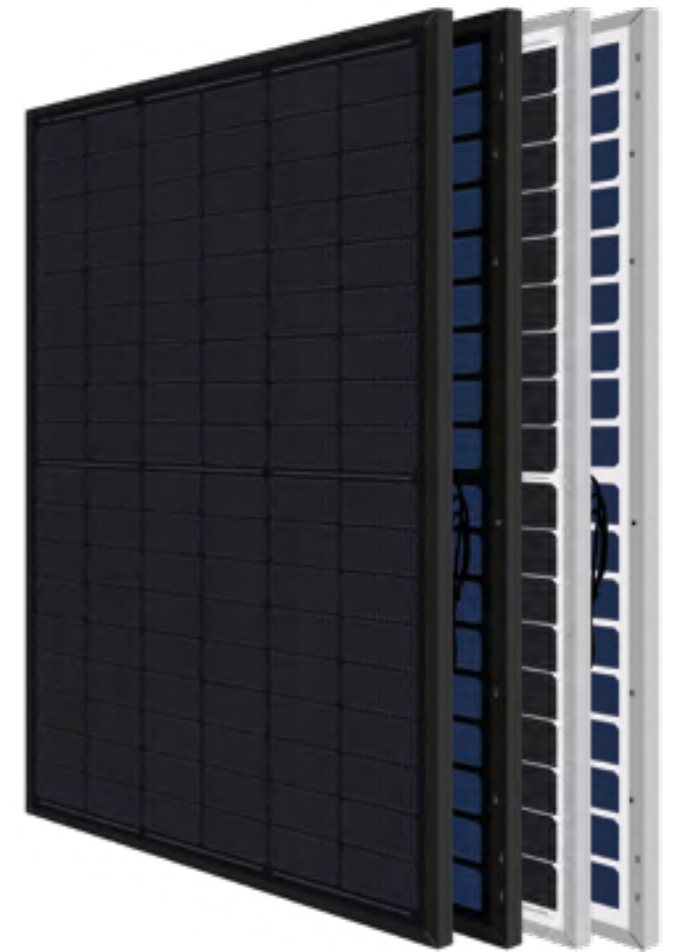

- Module efficiency**  
Module efficiency up to 22.52 %
- Different designs**  
Black - Silver
- Bifacial cell**  
Extra energy generated from the backside of the cell depending on albedo
- Fire rating**  
Class A
- PFAS free**  
Product free from perfluoroalkyl and polyfluoroalkyl substances
- Sustainable product**  
High percentage of recyclable materials

**25 Years**  
 Product Warranty  
 +5 years for Premium Partners

**30 Years**  
 Performance Warranty  
 Linear Warranty

**1%** First year degradation  
**0.38%** Annual degradation  
**88%** Power in year 30

**Light up your world with Eurener**

Eurener's extensive portfolio of certifications and awards is testament to our unwavering commitment to our partners and our deep sense of social and ethical responsibility.



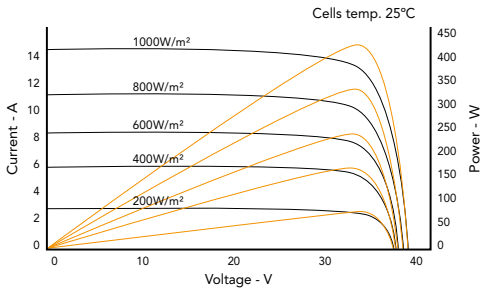
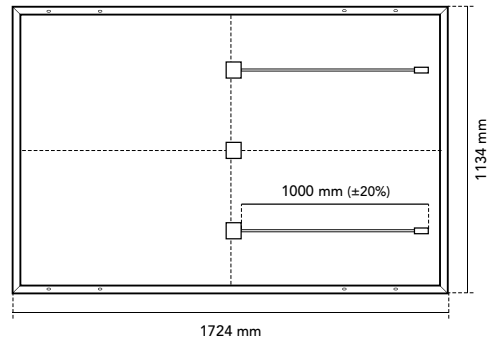

Mechanical Specification	
Solar cells	N-Type bifacial monocrystalline silicon cells
Front Glass	2mm anti-reflective surface tempered solar glass
Back Glass	2mm tempered solar glass
Frame	Black/silver anodized aluminium
Junction Box	IP68, 3 by-pass diodes
Connector	Original MC4-Evo 2
Cable	1000 mm (±20%) length and 4 mm <sup>2</sup> section
Dimension	1724 x 1134 x 30 mm (±1%)
Area	1.96 m <sup>2</sup>
Weight	24 kg
Packaging	962 pcs/truck

Temperature Coefficients	
Temperature coefficient of Isc (α)	0.045 %/°C
Temperature coefficient of Voc (β)	-0.275 %/°C
Temperature coefficient of Pmax (γ)	-0.29 %/°C
Temperature range	-40 °C ~ +85 °C
Nominal operating cell temperature (NOCT)	45 ± 2 °C

Electrical Characteristics	MEPV 420		MEPV 425		MEPV 430		MEPV 435		MEPV 440	
	STC	NOCT	STC	NOCT	STC	NOCT	STC	NOCT	STC	NOCT
Nominal power. Pmax	420 Wp	322 Wp	425 Wp	325 Wp	430 Wp	329 Wp	435 Wp	333 Wp	440 Wp	337 Wp
Short-circuit current (Isc)	14.08 A	11.34 A	14.16 A	11.41 A	14.26 A	11.47 A	14.30 A	11.54 A	14.37 A	11.61 A
Open-circuit voltage (Voc)	38.09 V	36.52 V	38.28 V	36.70 V	38.42 V	36.88 V	38.70 V	37.06 V	38.91 V	37.24 V
Maximum power current (Imp)	13.34 A	10.75 A	13.42 A	10.81 A	13.52 A	10.88 A	13.56 A	10.94 A	13.63 A	11.01 A
Maximum power voltage (Vmp)	31.49 V	29.92 V	31.68 V	30.10 V	31.82 V	30.27 V	32.09 V	30.45 V	32.30 V	30.63 V
Module efficiency	21.49 %		21.75%		22.01%		22.26%		22.52 %	

Electrical Characteristics	Bifacial gain 10%				
	Nominal power. Pmax	462 Wp	468 Wp	473 Wp	479 Wp
Short-circuit current (Isc)	15.43 A	15.52 A	15.63 A	15.67 A	15.81 A
Open-circuit voltage (Voc)	38.09 V	38.31 V	38.49 V	38.85V	38.91 V
Maximum power current (Imp)	14.63 A	14.72 A	14.82 A	14.86 A	14.99 A
Maximum power voltage (Vmp)	31.58 V	31.76 V	31.91 V	32.21 V	32.30 V

\* STC: 1000 W/m<sup>2</sup>, module temperature 25°C, AM 1.5  
 \* NOCT: 800 W/m<sup>2</sup>, ambient temperature 20°C, AM 1.5

Operating parameters	
Maximum voltage	1000 - 1500 V
Maximum series fuse rating. Ir	25 A
Power output tolerance	0 - +3%
Voc and Isc tolerance	±3%
Fire rating	Class A (UL 790)
Protection class	Class II (IEC 61140)
Mechanical loads	Front load 5400 Pa, Back load 2400 Pa

Corporate and product certificates	
ECOVADIS rating - Platinum medal (TOP 1%)	
Solar Industry Forced Labor Prevention Pledge by SEIA	
ISO9001:2015 - Quality Management Systems	
ISO14001:2015 - Environmental Management System	
WEEE compliance in Germany	
PV CYCLE Italy	
IEC 61215 - Terrestrial photovoltaic (PV) modules - Design qualification and type approval	
IEC 61730 - Photovoltaic (PV) module safety qualification	
IEC 61701 - Photovoltaic (PV) modules - Salt mist corrosion testing	
IEC 62716 - Photovoltaic (PV) modules - Ammonia corrosion testing	
IEC TS 62804 - Photovoltaic (PV) modules - Test methods for the detection of potential-induced degradation	
Hail resistance HW3/RG3	
Certificate of Factory Production Control (UK) - MCS	
Fire reaction class: 1 - LAPI	
Assessed by Sundahus	



NOTE: Read the safety and installation manual before using the product. This data sheet is not legally binding, Eurener reserves the right of final interpretation. Eurener reserves the right to change the product characteristics and/or specifications without prior notice. The latest versions of all documents can always be found on our website at [www.eurener.com](http://www.eurener.com).

**SINCE 1997**  
 more than energy

**eurener.com**  
 contact@eurenerworld.com  
 +34 960 045 515  
 Calle Colón, 1-23  
 46004, Valencia, Spain

**European Experts in Residential modules**

Since 1997 our main purpose has been to supply quality and long-lasting photovoltaic modules that allow us and future generations, to continue generating clean energy to take care of our planet.

**Nexa TOPCon N-type**  
**> 480 - 500W**



- +23.1%** **Module efficiency**  
Module efficiency up to 23.10 %
- Different designs**  
Black - Silver
- PID resistance**  
Certified according to IEC TS 62804 standards
- Increased resistance**  
Certified resistance against salt mist and ammonia
- Hail resistance**  
RG3/HW3 certified
- Better temperature coefficient**  
Minimized thermal losses, improved efficiency

**20 Years**  
**Product Warranty**  
 +5 years for Premium Partners

**30 Years**  
**Performance Warranty**  
 Linear Warranty

**1%** First year degradation  
**0.38%** Annual degradation  
**88%** Power in year 30

**Light up your world with Eurener**

Eurener's extensive portfolio of certifications and awards is testament to our unwavering commitment to our partners and our deep sense of social and ethical responsibility.





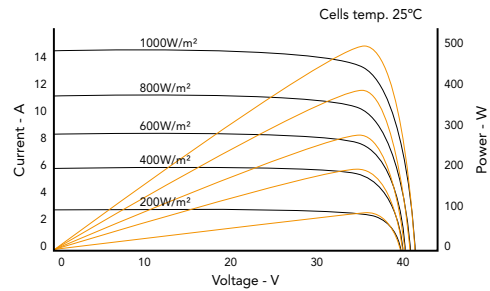
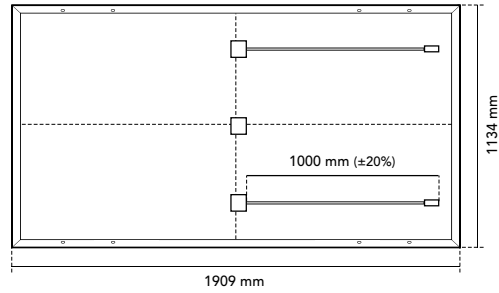

**Mechanical Specification**

Solar cells	N-Type monocrystalline silicon cells
Front Glass	3.2 mm thick tempered glass with high strength and ARC
Frame	Black/silver anodized aluminium
Junction Box	IP68, 3 by-pass diodes
Connector	Original MC4-Evo 2
Cable	1000 mm (±20%) length and 4 mm <sup>2</sup> section
Dimension	1909 x 1134 x 30 mm (±1%)
Area	2.16 m <sup>2</sup>
Weight	25.9 kg
Packaging	864 pcs/truck

**Temperature Coefficients**

Temperature coefficient of Isc (α)	0.045 %/°C
Temperature coefficient of Voc (β)	-0.275 %/°C
Temperature coefficient of Pmax (γ)	-0.29 %/°C
Temperature range	-40 °C ~ +85 °C
Nominal operating cell temperature (NOCT)	45 ± 2 °C

	MEPV 480	MEPV 490	MEPV 500
<b>Electrical Characteristics</b>			
STC			
Nominal power. Pmax	480 Wp	490 Wp	500 Wp
Short-circuit current (Isc)	14.34 A	14.44 A	14.52 A
Open-circuit voltage (Voc)	42.63 V	42.95 V	43.25 V
Maximum power current (Imp)	13.60 A	13.78 A	13.94 A
Maximum power voltage (Vmp)	35.31 V	35.61 V	35.88 V
Module efficiency	22.18 %	22.63 %	23.10 %
<b>Electrical Characteristics</b>			
NOCT			
Nominal power. Pmax	361 Wp	369 Wp	376 Wp
Short-circuit current (Isc)	11.55 A	11.69 A	11.81 A
Open-circuit voltage (Voc)	40.57 V	41.02 V	41.43 V
Maximum power current (Imp)	10.85 A	11.01 A	11.13 A
Maximum power voltage (Vmp)	33.27 V	33.48 V	33.80 V

\* STC: 1000 W/m<sup>2</sup>, module temperature 25°C, AM 1.5  
 \* NOCT: 800 W/m<sup>2</sup>, ambient temperature 20°C, AM 1.5

**Operating parameters**

Maximum voltage	1500 V
Maximum series fuse rating. Ir	25 A
Power output tolerance	0 - +3%
Voc and Isc tolerance	±3%
Fire rating	Class C (UL 790)
Protection class	Class II (IEC 61140)
Mechanical loads	Front load 5400 Pa, Back load 2400 Pa

**Corporate and product certificates**

ECOVADIS rating - Platinum medal (TOP 1%)
Solar Industry Forced Labor Prevention Pledge by SEIA
ISO9001:2015 - Quality Management Systems
ISO14001:2015 - Environmental Management System
WEEE compliance in Germany
PV CYCLE Italy
IEC 61215 - Terrestrial photovoltaic (PV) modules - Design qualification and type approval
IEC 61730 - Photovoltaic (PV) module safety qualification
IEC 61701 - Photovoltaic (PV) modules - Salt mist corrosion testing
IEC 62716 - Photovoltaic (PV) modules - Ammonia corrosion testing
IEC TS 62804 - Photovoltaic (PV) modules - Test methods for the detection of potential-induced degradation
Hail resistance HW3/RG3
Certificate of Factory Production Control (UK) - MCS
Fire reaction class: 1 - LAPI



NOTE: Read the safety and installation manual before using the product. This data sheet is not legally binding, Eurener reserves the right of final interpretation. Eurener reserves the right to change the product characteristics and/or specifications without prior notice. The latest versions of all documents can always be found on our website at [www.eurener.com](http://www.eurener.com).

**SINCE 1997**  
 more than energy

**eurener.com**  
 contact@eurenerworld.com  
 +34 960 045 515  
 Calle Colón, 1-23  
 46004, Valencia, Spain

**European Experts in Residential modules**

Since 1997 our main purpose has been to supply quality and long-lasting photovoltaic modules that allow us and future generations, to continue generating clean energy to take care of our planet.

**Nexa TOPCon N-type**

**FRONT SIDE**  
**480 - 500W**

› Double Glass Bifacial

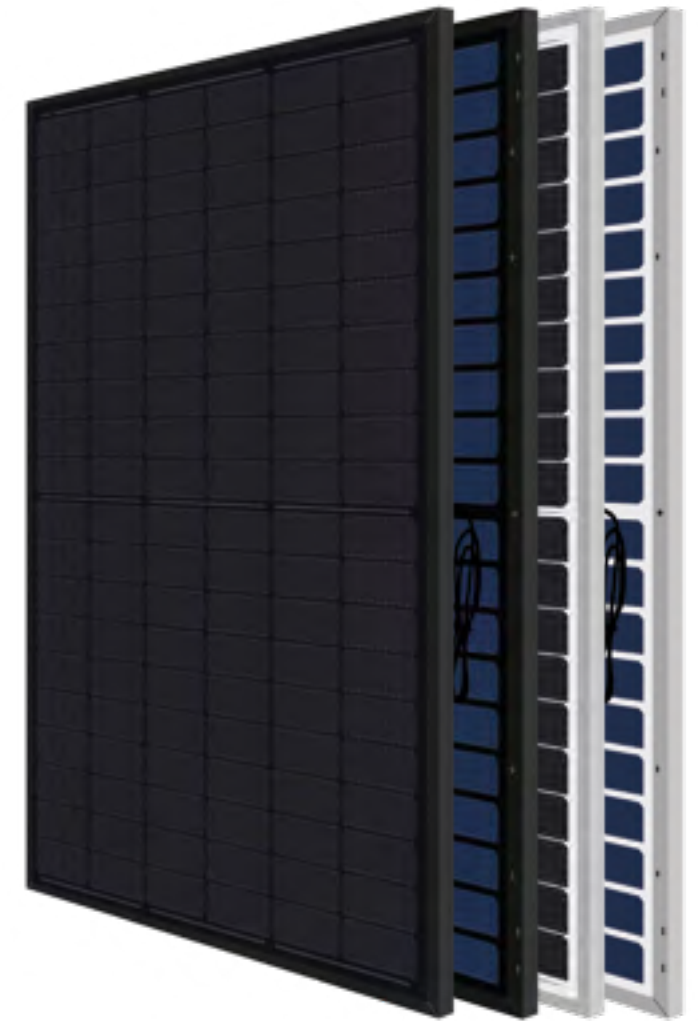

- +23.1%** **Module efficiency**  
Module efficiency up to 23.10 %
- Different designs**  
Black - Silver
- Bifacial cell**  
Extra energy generated from the backside of the cell depending on albedo
- Fire rating**  
Class A
- PFAS free**  
Product free from perfluoroalkyl and polyfluoroalkyl substances
- Sustainable product**  
High percentage of recyclable materials

**25 Years**  
**Product Warranty**  
 +5 years for Premium Partners

**30 Years**  
**Performance Warranty**  
 Linear Warranty

**1%** First year degradation  
**0.38%** Annual degradation  
**88%** Power in year 30

**Light up your world with Eurener**

Eurener's extensive portfolio of certifications and awards is testament to our unwavering commitment to our partners and our deep sense of social and ethical responsibility.





# Eurener MEPV — NEXA Double Glass Bifacial 480-500W

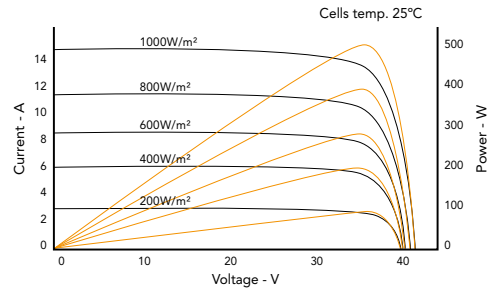
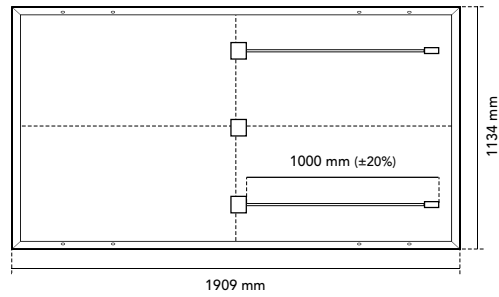

### Mechanical Specification

Solar cells	N-Type bifacial monocrystalline silicon cells
Front Glass	2mm anti-reflective surface tempered solar glass
Back Glass	2mm tempered solar glass
Frame	Black/silver anodized aluminium
Junction Box	IP68, 3 by-pass diodes
Connector	Original MC4-Evo 2
Cable	1000 mm (±20%) length and 4 mm <sup>2</sup> section
Dimension	1909 x 1134 x 30 mm (±1%)
Area	2.16 m <sup>2</sup>
Weight	27 kg
Packaging	864 pcs/truck

### Temperature Coefficients

Temperature coefficient of Isc (α)	0.045 %/°C
Temperature coefficient of Voc (β)	-0.275 %/°C
Temperature coefficient of Pmax (γ)	-0.29 %/°C
Temperature range	-40 °C ~ +85 °C
Nominal operating cell temperature (NOCT)	45 ± 2 °C

Electrical Characteristics	MEPV 480		MEPV 490		MEPV 500	
	STC	NOCT	STC	NOCT	STC	NOCT
Nominal power, Pmax	480 Wp	361 Wp	490 Wp	369 Wp	500 Wp	376 Wp
Short-circuit current (Isc)	14.34 A	11.55 A	14.44 A	11.69 A	14.52 A	11.81 A
Open-circuit voltage (Voc)	42.63 V	40.57 V	42.95 V	41.02 V	43.25 V	41.43 V
Maximum power current (Imp)	13.60 A	10.85 A	13.78 A	11.01 A	13.94 A	11.13 A
Maximum power voltage (Vmp)	35.31 V	33.27 V	35.61 V	33.48 V	35.88 V	33.80 V
Module efficiency	22.18 %		22.63 %		23.10 %	

Electrical Characteristics	Bifacial gain 10%		
	MEPV 480	MEPV 490	MEPV 500
Nominal power, Pmax	528 Wp	539 Wp	550 Wp
Short-circuit current (Isc)	15.72 A	15.93 A	16.02 A
Open-circuit voltage (Voc)	42.71 V	43.03 V	43.31 V
Maximum power current (Imp)	14.91 A	15.11 A	15.30 A
Maximum power voltage (Vmp)	35.42 V	35.68 V	35.97 V

\* STC: 1000 W/m<sup>2</sup>, module temperature 25°C, AM 1.5  
 \* NOCT: 800 W/m<sup>2</sup>, ambient temperature 20°C, AM 1.5

Operating parameters	
Maximum voltage	1500 V
Maximum series fuse rating, Ir	25 A
Power output tolerance	0 - +3%
Voc and Isc tolerance	±3%
Fire rating	Class A (UL 790)
Protection class	Class II (IEC 61140)
Mechanical loads	Front load 5400 Pa, Back load 2400 Pa

### Corporate and product certificates

- ECOVADIS rating - Platinum medal (TOP 1%)
- Solar Industry Forced Labor Prevention Pledge by SEIA
- ISO9001:2015 - Quality Management Systems
- ISO14001:2015 - Environmental Management System
- WEEE compliance in Germany
- PV CYCLE Italy
- IEC 61215 - Terrestrial photovoltaic (PV) modules - Design qualification and type approval
- IEC 61730 - Photovoltaic (PV) module safety qualification
- IEC 61701 - Photovoltaic (PV) modules - Salt mist corrosion testing
- IEC 62716 - Photovoltaic (PV) modules - Ammonia corrosion testing
- IEC TS 62804 - Photovoltaic (PV) modules - Test methods for the detection of potential-induced degradation
- Hail resistance HW3/RG3
- Certificate of Factory Production Control (UK) - MCS
- Fire reaction class: 1 - LAPI



NOTE: Read the safety and installation manual before using the product. This data sheet is not legally binding, Eurener reserves the right of final interpretation. Eurener reserves the right to change the product characteristics and/or specifications without prior notice. The latest versions of all documents can always be found on our website at [www.eurener.com](http://www.eurener.com).

**SINCE 1997**  
 more than energy

**eurener.com**  
 contact@eurenerworld.com  
 +34 960 045 515  
 Calle Colón, 1-23  
 46004, Valencia, Spain

**European Experts in Residential modules**

Since 1997 our main purpose has been to supply quality and long-lasting photovoltaic modules that allow us and future generations, to continue generating clean energy to take care of our planet.



European Experts  
 in Residential Modules

## Nexa Plus TOPCon N-type

# > 570 - 580W



- +22.4% Module efficiency**  
Module efficiency up to 22.47 %
- Different designs**  
Black - Silver
- PID resistance**  
Certified according to IEC TS 62804 standards
- Salt mist resistance**  
Certified according to IEC 61701 standards
- Hail resistance**  
RG3/HW3 certified
- Increased PV surface**  
Higher power output for commercial and ground projects

**20 Years**  
 Product Warranty  
 +5 years for Premium Partners

**30 Years**  
 Performance Warranty  
 Linear Warranty

**1%** First year degradation  
**0.38%** Annual degradation  
**88%** Power in year 30

**Light up your world with Eurener**

Eurener's extensive portfolio of certifications and awards is testament to our unwavering commitment to our partners and our deep sense of social and ethical responsibility.





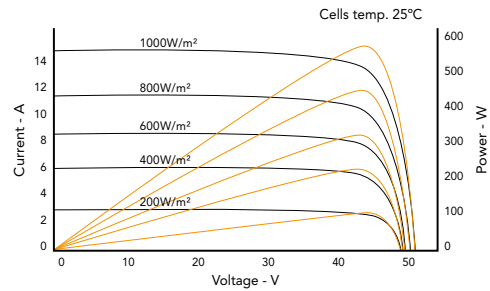
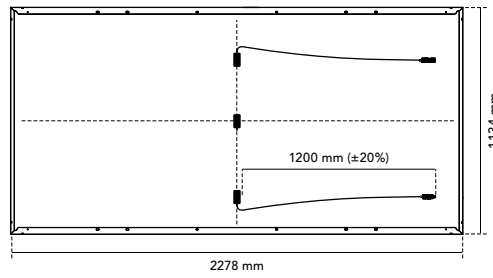

**Mechanical Specification**

Solar cells	N-Type monocrystalline silicon cells
Front Glass	3.2 mm thick tempered glass with high strength and ARC
Frame	Black/silver anodized aluminium
Junction Box	IP68, 3 by-pass diodes
Connector	Original MC4-Evo 2 / MC4 compatible
Cable	1200 mm (±20%) length and 4 mm <sup>2</sup> section
Dimension and packaging	2278 x 1134 x 30 mm (±1%) > 720 pcs/truck 2278 x 1134 x 35 mm (±1%) > 620 pcs/truck
Area	2.58 m <sup>2</sup>
Weight	28 kg

**Temperature Coefficients**

Temperature coefficient of Isc (α)	0.045 %/°C
Temperature coefficient of Voc (β)	-0.275 %/°C
Temperature coefficient of Pmax (γ)	-0.29 %/°C
Temperature range	-40 °C ~ +85 °C
Nominal operating cell temperature (NOCT)	45 ± 2 °C

	MEPV 570	MEPV 575	MEPV 580
<b>Electrical Characteristics</b>			
STC			
Nominal power. Pmax	570 Wp	575 Wp	580 Wp
Short-circuit current (Isc)	14.27 A	14.42 A	14.49 A
Open-circuit voltage (Voc)	50.67 V	50.86 V	51.07 V
Maximum power current (Imp)	13.52 A	13.61 A	13.70 A
Maximum power voltage (Vmp)	42.16 V	42.25 V	42.35 V
Module efficiency	22.03 %	22.29 %	22.47 %
<b>Electrical Characteristics</b>			
NOCT			
Nominal power. Pmax	429 Wp	432 Wp	436 Wp
Short-circuit current (Isc)	11.56 A	11.61 A	11.69 A
Open-circuit voltage (Voc)	48.26 V	48.28 V	48.38 V
Maximum power current (Imp)	10.88 A	10.89 A	10.99 A
Maximum power voltage (Vmp)	39.41 V	39.68 V	39.70 V

\* STC: 1000 W/m<sup>2</sup>, module temperature 25°C, AM 1.5  
\* NOCT: 800 W/m<sup>2</sup>, ambient temperature 20°C, AM 1.5

**Operating parameters**

Maximum voltage	1500 V
Maximum series fuse rating. Ir	25 A
Power output tolerance	0 - +3%
Voc and Isc tolerance	±3%
Fire rating	Class C (UL 790)
Protection class	Class II (IEC 61140)
Mechanical loads	Front load 5400 Pa, Back load 2400 Pa

**Corporate and product certificates**

ECOVADIS rating - Platinum medal (TOP 1%)
Solar Industry Forced Labor Prevention Pledge by SEIA
ISO9001:2015 - Quality Management Systems
ISO14001:2015 - Environmental Management System
WEEE compliance in Germany
PV CYCLE Italy
IEC 61215 - Terrestrial photovoltaic (PV) modules - Design qualification and type approval
IEC 61730 - Photovoltaic (PV) module safety qualification
IEC 61701 - Photovoltaic (PV) modules - Salt mist corrosion testing
IEC 62716 - Photovoltaic (PV) modules - Ammonia corrosion testing
IEC TS 62804 - Photovoltaic (PV) modules - Test methods for the detection of potential-induced degradation
Hail resistance HW3/RG3
Certificate of Factory Production Control (UK) - MCS
Fire reaction class: 1 - LAPI



NOTE: Read the safety and installation manual before using the product. This data sheet is not legally binding, Eurener reserves the right of final interpretation. Eurener reserves the right to change the product characteristics and/or specifications without prior notice. The latest versions of all documents can always be found on our website at [www.eurener.com](http://www.eurener.com).

**SINCE 1997**  
more than energy

**eurener.com**  
contact@eurenerworld.com  
+34 960 045 515  
Calle Colón, 1-23  
46004, Valencia, Spain

**European Experts in Residential modules**

Since 1997 our main purpose has been to supply quality and long-lasting photovoltaic modules that allow us and future generations, to continue generating clean energy to take care of our planet.

**Nexa Plus TOPCon N-type**

FRONT SIDE  
**690 - 700W**

> Double Glass Bifacial

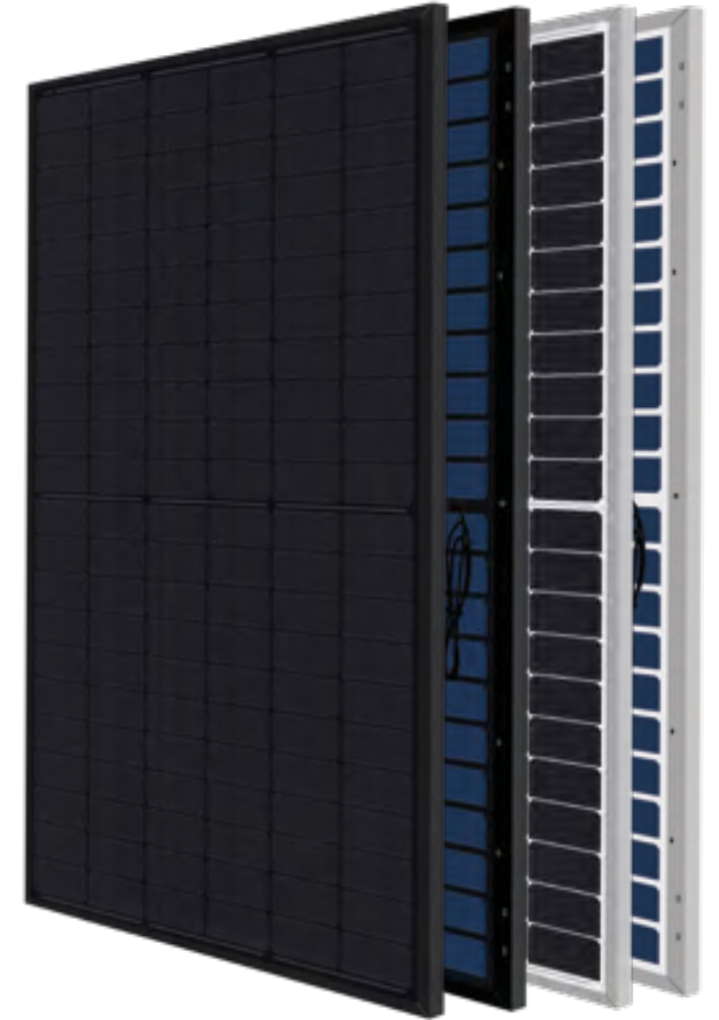

- +22.5% Module efficiency**  
Module efficiency up to 22.52 %
- Bifacial cell**  
Extra energy generated from the backside of the cell depending on albedo
- Fire rating**  
Class A
- PFAS free**  
Product free from perfluoroalkyl and polyfluoroalkyl substances
- Sustainable product**  
High percentage of recyclable materials
- Optimized BOS**  
Lower structure, materials and wiring costs

**25 Years**  
Product Warranty  
+5 years for Premium Partners

**30 Years**  
Performance Warranty  
Linear Warranty

**1% First year degradation**  
**0.38% Annual degradation**  
**88% Power in year 30**

**Light up your world with Eurener**

Eurener's extensive portfolio of certifications and awards is testament to our unwavering commitment to our partners and our deep sense of social and ethical responsibility.





# Eurener MEPV — NEXA Plus Double Glass Bifacial 690-700W

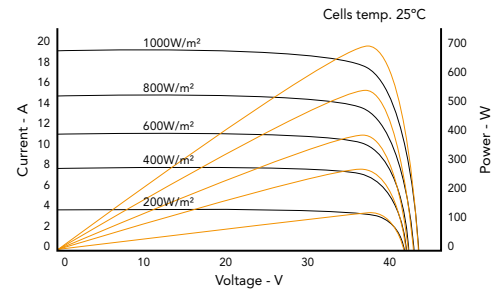
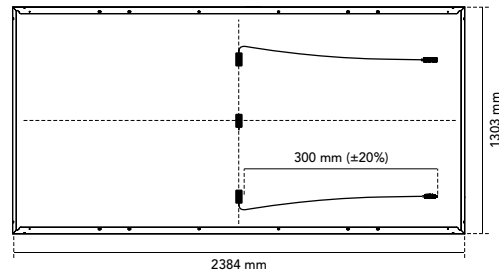

### Mechanical Specification

Solar cells	N-Type bifacial monocrystalline silicon cells
Front Glass	2mm anti-reflective surface tempered solar glass
Back Glass	2mm tempered solar glass
Frame	Black/silver anodized aluminium
Junction Box	IP68, 3 by-pass diodes
Connector	Original MC4-Evo 2 / MC4 compatible
Cable	300 mm (±20%) length and 4 mm <sup>2</sup> section
Dimension	2384 x 1303 x 35 mm (±1%)
Area	3.11 m <sup>2</sup>
Weight	38 kg
Packaging	558 pcs/truck

### Temperature Coefficients

Temperature coefficient of Isc (α)	0.046 %/°C
Temperature coefficient of Voc (β)	-0.26 %/°C
Temperature coefficient of Pmax (γ)	-0.3 %/°C
Temperature range	-40 °C ~ +85 °C
Nominal operating cell temperature (NOCT)	42 ± 2 °C

Electrical Characteristics	MEPV 690		MEPV 700	
	STC	NOCT	STC	NOCT
Nominal power. Pmax	690 Wp	521 Wp	700 Wp	529 Wp
Short-circuit current (Isc)	18.80 A	15.17 A	18.92 A	15.25 A
Open-circuit voltage (Voc)	46.86 V	44.84 V	47.35 V	45.19 V
Maximum power current (Imp)	17.75 A	14.26 A	17.78 A	14.33 A
Maximum power voltage (Vmp)	38.93 V	36.58 V	39.43 V	36.95 V
Module efficiency	22.22 %		22.52 %	

Electrical Characteristics	Bifacial gain 10%	
Nominal power. Pmax	759 W	770 W
Short-circuit current (Isc)	20.68 A	20.81 A
Open-circuit voltage (Voc)	46.86 V	47.35 V
Maximum power current (Imp)	19.50 A	19.53 A
Maximum power voltage (Vmp)	38.93 V	39.43 V

\* STC: 1000 W/m<sup>2</sup>, module temperature 25°C, AM 1.5  
 \* NOCT: 800 W/m<sup>2</sup>, ambient temperature 20°C, AM 1.5

Operating parameters	
Maximum voltage	1500 V
Maximum series fuse rating. Ir	30 A
Power output tolerance	0 - +3%
Voc and Isc tolerance	±3%
Fire rating	Class A (UL 790)
Protection class	Class II (IEC 61140)
Mechanical loads	Front load 5400 Pa, Back load 2400 Pa

### Corporate and product certificates

- ECOVADIS rating - Platinum medal (TOP 1%)
- Solar Industry Forced Labor Prevention Pledge by SEIA
- ISO9001:2015 - Quality Management Systems
- ISO14001:2015 - Environmental Management System
- WEEE compliance in Germany
- PV CYCLE Italy
- IEC 61215 - Terrestrial photovoltaic (PV) modules - Design qualification and type approval
- IEC 61730 - Photovoltaic (PV) module safety qualification
- IEC 61701 - Photovoltaic (PV) modules - Salt mist corrosion testing
- IEC 62716 - Photovoltaic (PV) modules - Ammonia corrosion testing
- IEC TS 62804 - Photovoltaic (PV) modules - Test methods for the detection of potential-induced degradation
- Hail resistance HW3/RG3
- Certificate of Factory Production Control (UK) - MCS
- Fire reaction class: 1 - LAPI



NOTE: Read the safety and installation manual before using the product. This data sheet is not legally binding, Eurener reserves the right of final interpretation. Eurener reserves the right to change the product characteristics and/or specifications without prior notice. The latest versions of all documents can always be found on our website at [www.eurener.com](http://www.eurener.com).

**SINCE 1997**  
 more than energy

**eurener.com**  
 contact@eurenerworld.com  
 +34 960 045 515  
 Calle Colón, 1-23  
 46004, Valencia, Spain

**European Experts in Residential modules**

Since 1997 our main purpose has been to supply quality and long-lasting photovoltaic modules that allow us and future generations, to continue generating clean energy to take care of our planet.

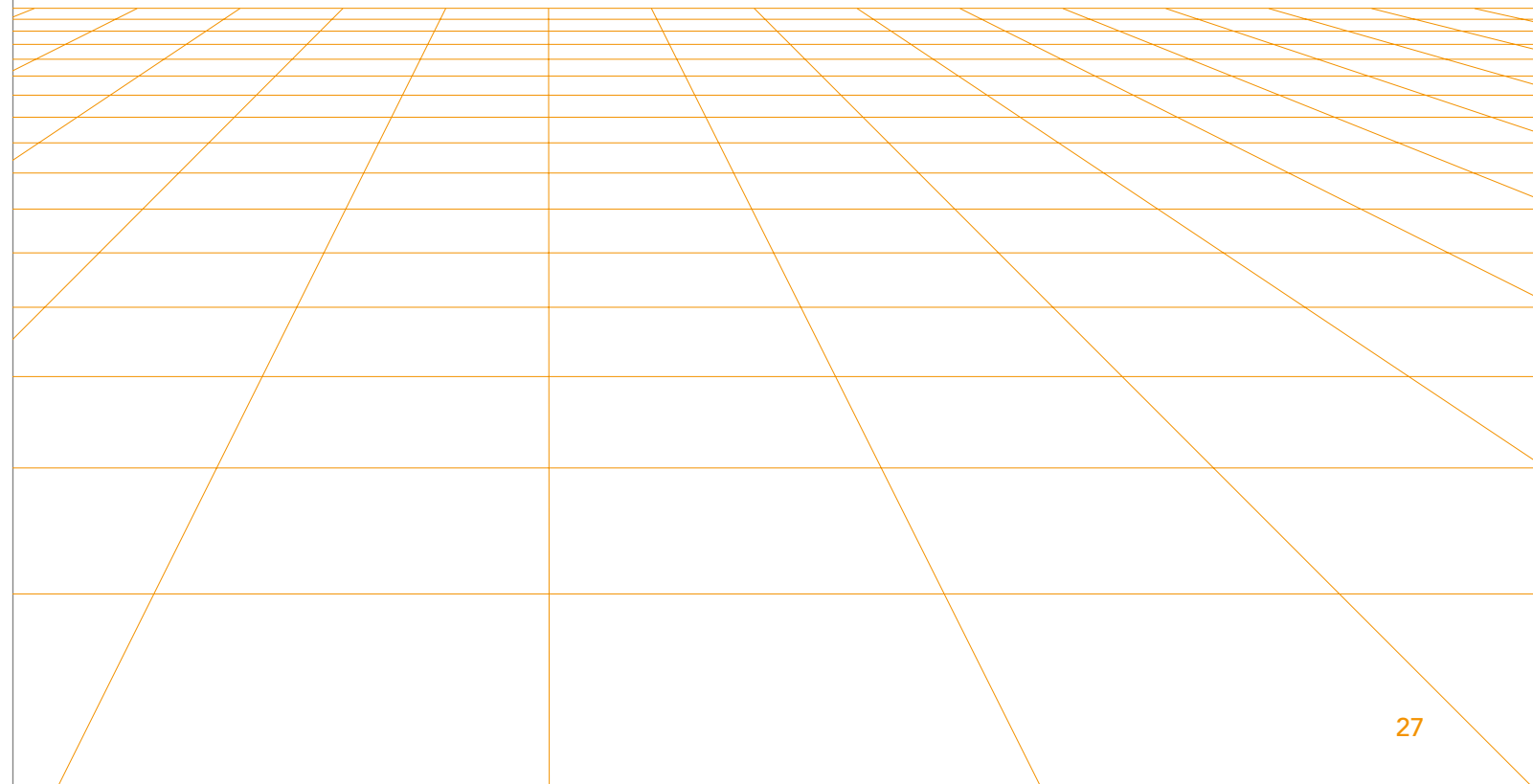





## MEPV ULTRA Series

↘ *Pure power. Pure elegance*

Solar elegance redefined. Bring sophistication to your home with our exclusive full-black solar panels designed for architectural integration. Groundbreaking technology, superior warranties, and higher efficiency for your property.

## ULTRA — BACK CONTACT N-TYPE TECHNOLOGY

› *from 400 to 460W*



### Back contact technology

Removing busbars from the front side reduces the effect of shadows on the solar cell.



### N-type cell

Due to their composition, offer higher performance and efficiency than P-type cells and reduce the LID and LeTID effects.



### Lower temperature impact

Modules with better temperature coefficient that reduces thermal losses and improves efficiency in hot climates.



### Premium integration

Total black appearance for a perfect commercial and residential rooftop integration.



### Optimized area (<math><2\text{m}^2</math>)

Perfect size for comfortable installations and easy handling.

Maintaining suitable power outputs.

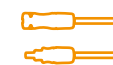

### Original MC4 - Evo2

Modules manufactured with original MC4-EVO 2 connectors by default, adding extra security and reliability to the PV system.

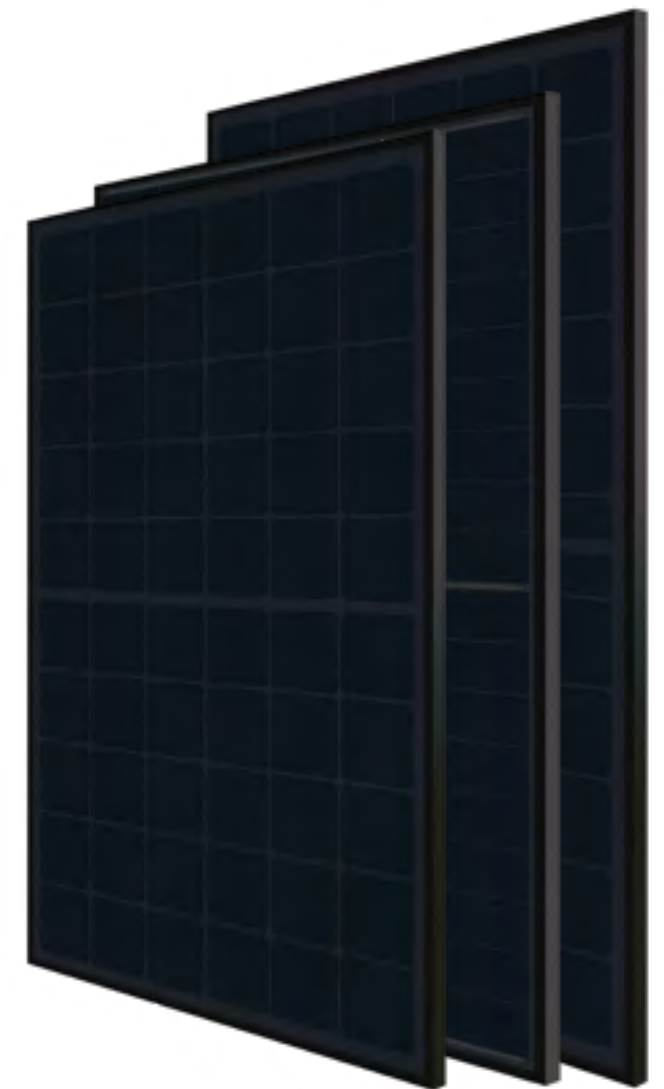



## MEPV Ultra Series

### DATA SHEETS

- › Eurener MEPV Ultra 400W  
*pag. 31/32*
- › Eurener MEPV Ultra 440W  
*pag. 33/34*
- › Eurener MEPV Ultra 450-460W  
*pag. 35/36*
- › Eurener MEPV Ultra DG 450-460W  
*pag. 37/38*



European Experts  
in Residential Modules

## Ultra Back Contact N-type

# > 400W



### Module efficiency

Module efficiency up to 22.31 %



### Elegant design

Cells free from frontal metallization



### PID resistance

Certified according to IEC TS 62804 standards



### Increased resistance

Certified resistance against salt mist and ammonia



### Hail resistance

RG3/HW3 certified



### Easy to handle

Comfortable installation thanks to an optimized area size

# 20

Years

Product Warranty

+5 years for Premium Partners

# 30

Years

Performance Warranty

Linear Warranty

1% First year degradation

0.21% Annual degradation

93% Power in year 30

### Light up your world with Eurener

Eurener's extensive portfolio of certifications and awards is testament to our unwavering commitment to our partners and our deep sense of social and ethical responsibility.





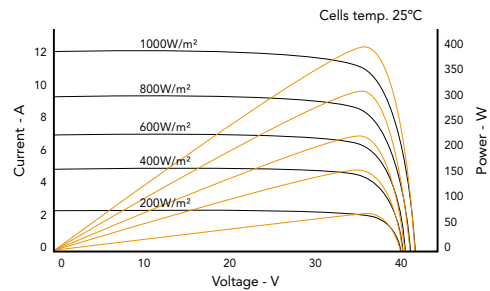
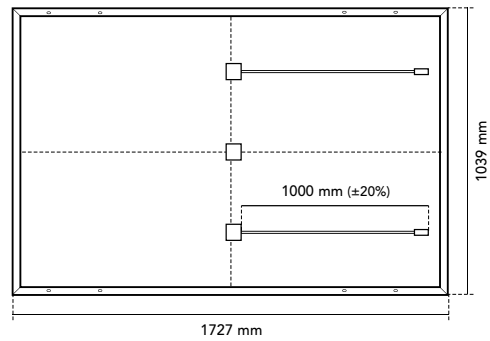

Mechanical Specification	
Solar cells	N-Type monocrystalline silicon cells
Front Glass	3.2 mm thick tempered glass with high strength and ARC
Frame	Black anodized aluminium
Junction Box	IP68, 3 by-pass diodes
Connector	Original MC4-Evo 2
Cable	1000 mm (±20%) length and 4 mm <sup>2</sup> section
Dimension	1727 x 1039 x 30 mm (±1%)
Area	1.79 m <sup>2</sup>
Weight	20 kg
Packaging	949 pcs/truck

Temperature Coefficients	
Temperature coefficient of Isc (α)	0.045 %/°C
Temperature coefficient of Voc (β)	-0.247 %/°C
Temperature coefficient of Pmax (γ)	-0.29 %/°C
Temperature range	-40 °C ~ +85 °C
Nominal operating cell temperature (NOCT)	43 ± 2 °C

MEPV 400	
<b>Electrical Characteristics</b>	
Nominal power. Pmax	400 Wp
Short-circuit current (Isc)	12.05 A
Open-circuit voltage (Voc)	42.10 V
Maximum power current (Imp)	11.09 A
Maximum power voltage (Vmp)	36.10 V
Module efficiency	22.31 %
<b>Electrical Characteristics</b>	
Nominal power. Pmax	307 Wp
Short-circuit current (Isc)	9.72 A
Open-circuit voltage (Voc)	40.23 V
Maximum power current (Imp)	8.96 A
Maximum power voltage (Vmp)	34.23 V

\* STC: 1000 W/m<sup>2</sup>, module temperature 25°C, AM 1.5  
 \* NOCT: 800 W/m<sup>2</sup>, ambient temperature 20°C, AM 1.5

Operating parameters	
Maximum voltage	1500 V
Maximum series fuse rating. Ir	20 A
Power output tolerance	0 - +3%
Voc and Isc tolerance	±3%
Fire rating	Class C (UL 790)
Protection class	Class II (IEC 61140)
Mechanical loads	Front load 5400 Pa, Back load 2400 Pa

Corporate and product certificates	
ECOVDIS rating - Platinum medal (TOP 1%)	
Solar Industry Forced Labor Prevention Pledge by SEIA	
ISO9001:2015 - Quality Management Systems	
ISO14001:2015 - Environmental Management System	
WEEE compliance in Germany	
PV CYCLE Italy	
IEC 61215 - Terrestrial photovoltaic (PV) modules - Design qualification and type approval	
IEC 61730 - Photovoltaic (PV) module safety qualification	
IEC 61701 - Photovoltaic (PV) modules - Salt mist corrosion testing	
IEC 62716 - Photovoltaic (PV) modules - Ammonia corrosion testing	
IEC TS 62804 - Photovoltaic (PV) modules - Test methods for the detection of potential-induced degradation	
Hail resistance HW3/RG3	
Certificate of Factory Production Control (UK) - MCS	
Fire reaction class: 1 - LAPI	
Assessed by Sundahus	



NOTE: Read the safety and installation manual before using the product. This data sheet is not legally binding, Eurener reserves the right of final interpretation. Eurener reserves the right to change the product characteristics and/or specifications without prior notice. The latest versions of all documents can always be found on our website at [www.eurener.com](http://www.eurener.com).

**SINCE 1997**  
 more than energy

**eurener.com**  
 contact@eurenerworld.com  
 +34 960 045 515  
 Calle Colón, 1-23  
 46004, Valencia, Spain

**European Experts in Residential modules**

Since 1997 our main purpose has been to supply quality and long-lasting photovoltaic modules that allow us and future generations, to continue generating clean energy to take care of our planet.

## Ultra Back Contact N-type

# > 440W

- +22.3% Module efficiency**  
Module efficiency up to 22.37 %
- Elegant design**  
Cells free from frontal metallization
- PID resistance**  
Certified according to IEC TS 62804 standards
- Increased resistance**  
Certified resistance against salt mist and ammonia
- Hail resistance**  
RG3/HW3 certified
- Easy to handle**  
Comfortable installation thanks to an optimized area size



**20 Years**  
 Product Warranty  
 +5 years for Premium Partners

**30 Years**  
 Performance Warranty  
 Linear Warranty

**1%** First year degradation  
**0.21%** Annual degradation  
**93%** Power in year 30

### Light up your world with Eurener

Eurener's extensive portfolio of certifications and awards is testament to our unwavering commitment to our partners and our deep sense of social and ethical responsibility.



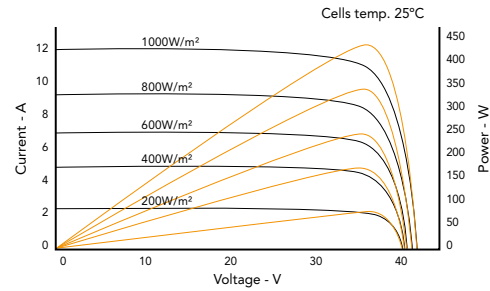
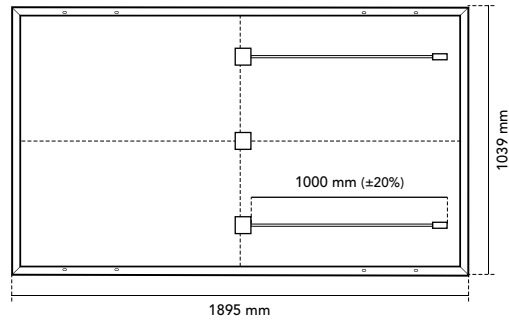

Mechanical Specification	
Solar cells	N-Type monocrystalline silicon cells
Front Glass	3.2 mm thick tempered glass with high strength and ARC
Frame	Black anodized aluminium
Junction Box	IP68, 3 by-pass diodes
Connector	Original MC4-Evo 2
Cable	1000 mm (±20%) length and 4 mm <sup>2</sup> section
Dimension	1895 x 1039 x 30 mm (±1%)
Area	1.97 m <sup>2</sup>
Weight	21 kg
Packaging	900 pcs/truck

Temperature Coefficients	
Temperature coefficient of Isc (α)	0.045 %/°C
Temperature coefficient of Voc (β)	-0.247 %/°C
Temperature coefficient of Pmax (γ)	-0.29 %/°C
Temperature range	-40 °C ~ +85 °C
Nominal operating cell temperature (NOCT)	43 ± 2 °C

MEPV 440	
<b>Electrical Characteristics</b>	
STC	
Nominal power. Pmax	440 Wp
Short-circuit current (Isc)	12.06 A
Open-circuit voltage (Voc)	46.30 V
Maximum power current (Imp)	11.12 A
Maximum power voltage (Vmp)	39.60 V
Module efficiency	22.37 %
<b>Electrical Characteristics</b>	
NOCT	
Nominal power. Pmax	337 Wp
Short-circuit current (Isc)	9.73 A
Open-circuit voltage (Voc)	44.24 V
Maximum power current (Imp)	8.98 A
Maximum power voltage (Vmp)	37.54 V

\* STC: 1000 W/m<sup>2</sup>, module temperature 25°C, AM 1.5  
 \* NOCT: 800 W/m<sup>2</sup>, ambient temperature 20°C, AM 1.5

Operating parameters	
Maximum voltage	1500 V
Maximum series fuse rating. Ir	20 A
Power output tolerance	0 - +3%
Voc and Isc tolerance	±3%
Fire rating	Class C (UL 790)
Protection class	Class II (IEC 61140)
Mechanical loads	Front load 5400 Pa, Back load 2400 Pa

Corporate and product certificates	
ECOVADIS rating - Platinum medal (TOP 1%)	
Solar Industry Forced Labor Prevention Pledge by SEIA	
ISO9001:2015 - Quality Management Systems	
ISO14001:2015 - Environmental Management System	
WEEE compliance in Germany	
PV CYCLE Italy	
IEC 61215 - Terrestrial photovoltaic (PV) modules - Design qualification and type approval	
IEC 61730 - Photovoltaic (PV) module safety qualification	
IEC 61701 - Photovoltaic (PV) modules - Salt mist corrosion testing	
IEC 62716 - Photovoltaic (PV) modules - Ammonia corrosion testing	
IEC TS 62804 - Photovoltaic (PV) modules - Test methods for the detection of potential-induced degradation	
Hail resistance HW3/RG3	
Certificate of Factory Production Control (UK) - MCS	
Fire reaction class: 1 - LAPI	



NOTE: Read the safety and installation manual before using the product. This data sheet is not legally binding, Eurener reserves the right of final interpretation. Eurener reserves the right to change the product characteristics and/or specifications without prior notice. The latest versions of all documents can always be found on our website at [www.eurener.com](http://www.eurener.com).

**SINCE 1997**  
 more than energy

**eurener.com**  
 contact@eurenerworld.com  
 +34 960 045 515  
 Calle Colón, 1-23  
 46004, Valencia, Spain

**European Experts in Residential modules**

Since 1997 our main purpose has been to supply quality and long-lasting photovoltaic modules that allow us and future generations, to continue generating clean energy to take care of our planet.

## Ultra Back Contact N-type

# > 450 - 460W



- +23.1% Module efficiency**  
Module efficiency up to 23.10 %
- Elegant design**  
Cells free from frontal metallization
- PID resistance**  
Certified according to IEC TS 62804 standards
- Increased resistance**  
Certified resistance against salt mist and ammonia
- Hail resistance**  
RG3/HW3 certified
- Easy to handle**  
Comfortable installation thanks to an optimized area size

**20 Years**  
**Product Warranty**  
 +5 years for Premium Partners

**30 Years**  
**Performance Warranty**  
 Linear Warranty

**1% First year degradation**  
**0.35% Annual degradation**  
**88.85% Power in year 30**

### Light up your world with Eurener

Eurener's extensive portfolio of certifications and awards is testament to our unwavering commitment to our partners and our deep sense of social and ethical responsibility.





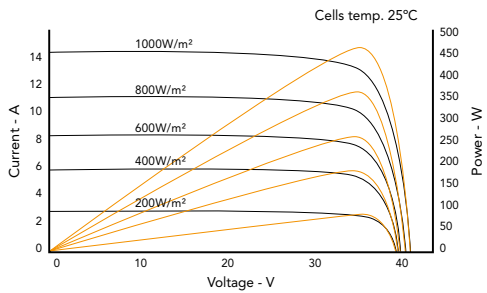
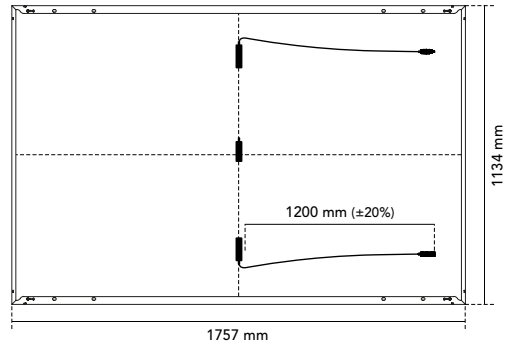

Mechanical Specification	
Solar cells	N-Type monocrystalline silicon cells
Front Glass	3.2 mm thick tempered glass with high strength and ARC
Frame	Black anodized aluminium
Junction Box	IP68, 3 by-pass diodes
Connector	Original MC4-Evo 2
Cable	1200 mm (±20%) length and 4 mm <sup>2</sup> section
Dimension	1757 x 1134 x 30 mm (±1%)
Area	1.99 m <sup>2</sup>
Weight	21.5 kg
Packaging	936 pcs/truck

Temperature Coefficients	
Temperature coefficient of Isc (α)	0.05 %/°C
Temperature coefficient of Voc (β)	-0.22 %/°C
Temperature coefficient of Pmax (γ)	-0.26 %/°C
Temperature range	-40 °C ~ +85 °C
Nominal operating cell temperature (NOCT)	45 ± 2 °C

Electrical Characteristics	MEPV 450	MEPV 455	MEPV 460
	STC		
Nominal power. Pmax	450 Wp	455 Wp	460 Wp
Short-circuit current (Isc)	14.03 A	14.11 A	14.26 A
Open-circuit voltage (Voc)	40.82 V	40.86 V	41.16 V
Maximum power current (Imp)	13.33 A	13.42 A	13.53 A
Maximum power voltage (Vmp)	33.77 V	33.93 V	34.01 V
Module efficiency	22.60 %	22.85 %	23.10 %
Electrical Characteristics	MEPV 450	MEPV 455	MEPV 460
	NOCT		
Nominal power. Pmax	339 Wp	343 Wp	346 Wp
Short-circuit current (Isc)	11.39 A	11.47 A	11.54 A
Open-circuit voltage (Voc)	38.63 V	38.72 V	38.89 V
Maximum power current (Imp)	10.60 A	10.70 A	10.81 A
Maximum power voltage (Vmp)	32.00 V	32.08 V	32.09 V

\* STC: 1000 W/m<sup>2</sup>, module temperature 25°C, AM 1.5  
 \* NOCT: 800 W/m<sup>2</sup>, ambient temperature 20°C, AM 1.5

Operating parameters	
Maximum voltage	1500 V
Maximum series fuse rating. Ir	25 A
Power output tolerance	0 - +3%
Voc and Isc tolerance	±3%
Fire rating	Class C (UL 790)
Protection class	Class II (IEC 61140)
Mechanical loads	Front load 5400 Pa, Back load 2400 Pa

Corporate and product certificates	
ECOVADIS rating - Platinum medal (TOP 1%)	
Solar Industry Forced Labor Prevention Pledge by SEIA	
ISO9001:2015 - Quality Management Systems	
ISO14001:2015 - Environmental Management System	
WEEE compliance in Germany	
PV CYCLE Italy	
IEC 61215 - Terrestrial photovoltaic (PV) modules - Design qualification and type approval	
IEC 61730 - Photovoltaic (PV) module safety qualification	
IEC 61701 - Photovoltaic (PV) modules - Salt mist corrosion testing	
IEC 62716 - Photovoltaic (PV) modules - Ammonia corrosion testing	
IEC TS 62804 - Photovoltaic (PV) modules - Test methods for the detection of potential-induced degradation	
Hail resistance HW3/RG3	
Certificate of Factory Production Control (UK) - MCS	
Fire reaction class: 1 - LAPI	



NOTE: Read the safety and installation manual before using the product. This data sheet is not legally binding, Eurener reserves the right of final interpretation. Eurener reserves the right to change the product characteristics and/or specifications without prior notice. The latest versions of all documents can always be found on our website at [www.eurener.com](http://www.eurener.com).

**SINCE 1997**  
 more than energy

**eurener.com**  
 contact@eurenerworld.com  
 +34 960 045 515  
 Calle Colón, 1-23  
 46004, Valencia. Spain

**European Experts in Residential modules**

Since 1997 our main purpose has been to supply quality and long-lasting photovoltaic modules that allow us and future generations, to continue generating clean energy to take care of our planet.

**Ultra Back Contact N-type**  
**450 - 460W**  
 > Double Glass



- +23.1%** **Module efficiency**  
Module efficiency up to 23.10 %
- Elegant design**  
Cells free from frontal metallization
- Sustainable product**  
High percentage of recyclable materials
- High reliability**  
Certified resistance against PID, salt mist and ammonia
- Better temperature coefficient**  
Minimized thermal losses, improved efficiency
- Easy to handle**  
Comfortable installation thanks to an optimized area size

**25 Years**  
**Product Warranty**  
 +5 years for Premium Partners

**30 Years**  
**Performance Warranty**  
 Linear Warranty

**1%** First year degradation  
**0.35%** Annual degradation  
**88.85%** Power in year 30

**Light up your world with Eurener**

Eurener's extensive portfolio of certifications and awards is testament to our unwavering commitment to our partners and our deep sense of social and ethical responsibility.





## Eurener MEPV — ULTRA Double Glass 450-460W

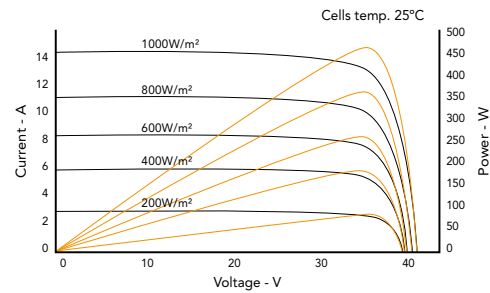
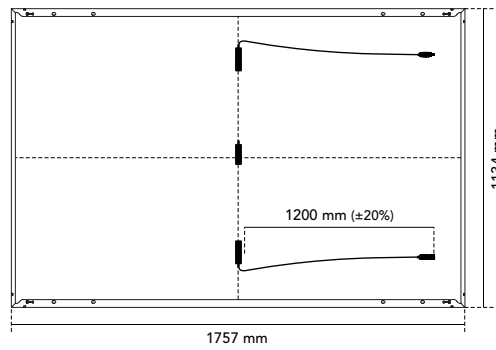

Mechanical Specification	
Solar cells	N-Type monocrystalline silicon cells
Front Glass	2mm anti-reflective surface tempered solar glass
Back Glass	2mm tempered solar glass
Frame	Black anodized aluminium
Junction Box	IP68, 3 by-pass diodes
Connector	Original MC4-Evo 2
Cable	1200 mm (±20%) length and 4 mm <sup>2</sup> section
Dimension	1757 x 1134 x 30 mm (±1%)
Area	1.99 m <sup>2</sup>
Weight	24.5 kg
Packaging	936 pcs/truck

Temperature Coefficients	
Temperature coefficient of Isc ( $\alpha$ )	0.05 %/°C
Temperature coefficient of Voc ( $\beta$ )	-0.22 %/°C
Temperature coefficient of Pmax ( $\gamma$ )	-0.26 %/°C
Temperature range	-40 °C ~ +85 °C
Nominal operating cell temperature (NOCT)	45 ± 2 °C

	MEPV 450	MEPV 455	MEPV 460
<b>Electrical Characteristics</b>			
STC			
Nominal power. Pmax	450 Wp	455 Wp	460 Wp
Short-circuit current (Isc)	14.03 A	14.11 A	14.26 A
Open-circuit voltage (Voc)	40.82 V	40.86 V	41.16 V
Maximum power current (Imp)	13.33 A	13.42 A	13.53 A
Maximum power voltage (Vmp)	33.77 V	33.93 V	34.01 V
Module efficiency	22.60 %	22.85 %	23.10 %
<b>Electrical Characteristics</b>			
NOCT			
Nominal power. Pmax	339 Wp	343 Wp	346 Wp
Short-circuit current (Isc)	11.39 A	11.47 A	11.54 A
Open-circuit voltage (Voc)	38.63 V	38.72 V	38.89 V
Maximum power current (Imp)	10.60 A	10.70 A	10.81 A
Maximum power voltage (Vmp)	32.00 V	32.08 V	32.09 V

\* STC: 1000 W/m<sup>2</sup>, module temperature 25°C, AM 1.5  
 \* NOCT: 800 W/m<sup>2</sup>, ambient temperature 20°C, AM 1.5

Operating parameters	
Maximum voltage	1500 V
Maximum series fuse rating. Ir	25 A
Power output tolerance	0 - +3%
Voc and Isc tolerance	±3%
Fire rating	Class C (UL 790)
Protection class	Class II (IEC 61140)
Mechanical loads	Front load 5400 Pa, Back load 2400 Pa

Corporate and product certificates	
ECOVADIS rating - Platinum medal (TOP 1%)	
Solar Industry Forced Labor Prevention Pledge by SEIA	
ISO9001:2015 - Quality Management Systems	
ISO14001:2015 - Environmental Management System	
WEEE compliance in Germany	
PV CYCLE Italy	
IEC 61215 - Terrestrial photovoltaic (PV) modules - Design qualification and type approval	
IEC 61730 - Photovoltaic (PV) module safety qualification	
IEC 61701 - Photovoltaic (PV) modules - Salt mist corrosion testing	
IEC 62716 - Photovoltaic (PV) modules - Ammonia corrosion testing	
IEC TS 62804 - Photovoltaic (PV) modules - Test methods for the detection of potential-induced degradation	
Hail resistance HW3/RG3	
Certificate of Factory Production Control (UK) - MCS	
Fire reaction class: 1 - LAPI	



NOTE: Read the safety and installation manual before using the product. This data sheet is not legally binding, Eurener reserves the right of final interpretation. Eurener reserves the right to change the product characteristics and/or specifications without prior notice. The latest versions of all documents can always be found on our website at [www.eurener.com](http://www.eurener.com).

**SINCE 1997**  
 more than energy

**eurener.com**  
 contact@eurenerworld.com  
 +34 960 045 515  
 Calle Colón, 1-23  
 46004, Valencia, Spain

**European Experts in Residential modules**

Since 1997 our main purpose has been to supply quality and long-lasting photovoltaic modules that allow us and future generations, to continue generating clean energy to take care of our planet.







## MEPV ICON Series

↳ *Versatile, reliable, timeless*

Manufactured in a wide range of finishes, this iconic solar module sets the industry standard. Designed to fit any installation, its multiple power options and sizes make it the perfect choice for any solar requirement.

## ICON — PERC TECHNOLOGY

› *from 340 to 550W*



### Half cut technology

The parallel connection of the half-cell modules maintains production when one of the parts is shaded.

This increases efficiency and reliability reducing the appearing of hot spots and dismisin cell degradation.



### Improved energy yield under unfavourable conditions

Cells capable of absorbing light during dawn and sunset.

Better response to diffuse light (dusty or cloudy skies).



### Project versatility

Modules that fit residential, industrial and large installations thanks to the different available sizes.



### Different designs

Customizable module aesthetics: Black - Silver - Bicolour.



### Resistance against PID

Certified according to IEC TS 62804-1:2015 standards.



### Hail resistance RG3/HW3

Certified resistance against hail impacts of 30 mm diameter at 23.9 m/s.





## MEPV Icon Series

### DATA SHEETS

- › Eurener MEPV Icon 340W  
*pag. 43/44*
- › Eurener MEPV Icon 375-380W  
*pag. 45/46*
- › Eurener MEPV Icon 400-420W  
*pag. 47/48*
- › Eurener MEPV Icon Plus 450-460W  
*pag. 49/50*
- › Eurener MEPV Icon Plus 500W  
*pag. 51/52*
- › Eurener MEPV Icon Plus 550W  
*pag. 53/54*
- › Eurener MEPV Icon Plus DG Bif 550W  
*pag. 55/56*



European Experts  
in Residential Modules

## Icon PERC

# > 340W

- Module efficiency**  
Module efficiency up to 21.17 %
- Different designs**  
Black - Silver - Bicolour
- PID resistance**  
Certified according to IEC TS 62804 standards
- Hail resistance**  
RG3/HW3 certified
- Easy to handle**  
Comfortable installation thanks to an optimized area size
- Wider irradiance range**  
Improved performance under dawn, sunset and cloudy skies



**20** Years  
Product Warranty  
+5 years for Premium Partners

**30** Years  
Performance Warranty  
Linear Warranty

- 2%** First year degradation
- 0.62%** Annual degradation
- 80%** Power in year 30

### Light up your world with Eurener

Eurener's extensive portfolio of certifications and awards is testament to our unwavering commitment to our partners and our deep sense of social and ethical responsibility.





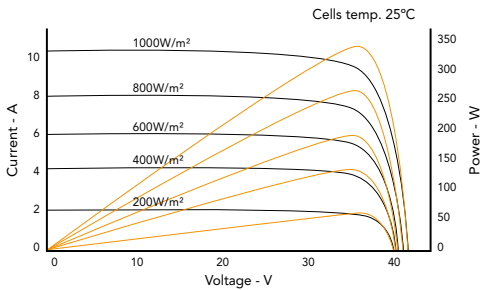
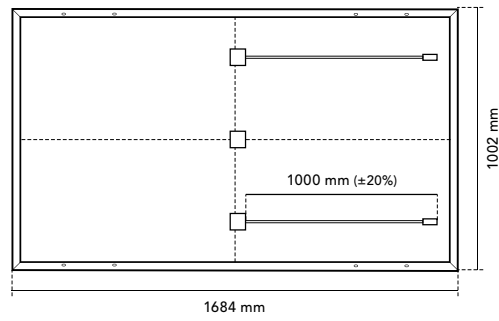

Mechanical Specification	
Solar cells	Monocrystalline silicon cells
Front Glass	3.2 mm thick tempered glass with high strength and ARC
Frame	Black/silver anodized aluminium
Junction Box	IP68, 3 by-pass diodes
Connector	Connector MC4 compatible
Cable	1000 mm (±20%) length and 4 mm <sup>2</sup> section
Dimension	1684 x 1002 x 35 mm (±1%)
Area	1.69 m <sup>2</sup>
Weight	18 kg
Packaging	858 pcs/truck

Temperature Coefficients	
Temperature coefficient of Isc (α)	0.04 %/°C
Temperature coefficient of Voc (β)	-0.26 %/°C
Temperature coefficient of Pmax (γ)	-0.36 %/°C
Temperature range	-40 °C ~ +85 °C
Nominal operating cell temperature (NOCT)	41 ± 3 °C

	MEPV 340
<b>Electrical Characteristics</b>	
	STC
Nominal power. Pmax	340 Wp
Short-circuit current (Isc)	10.26 A
Open-circuit voltage (Voc)	43.00 V
Maximum power current (Imp)	9.75 A
Maximum power voltage (Vmp)	34.90 V
Module efficiency	21.17 %
<b>Electrical Characteristics</b>	
	NOCT
Nominal power. Pmax	260 Wp
Short-circuit current (Isc)	8.26 A
Open-circuit voltage (Voc)	41.21 V
Maximum power current (Imp)	7.85 A
Maximum power voltage (Vmp)	33.11 V

\* STC: 1000 W/m<sup>2</sup>, module temperature 25°C, AM 1.5  
 \* NOCT: 800 W/m<sup>2</sup>, ambient temperature 20°C, AM 1.5

Operating parameters	
Maximum voltage	1000 - 1500 V
Maximum series fuse rating. Ir	20 A
Power output tolerance	0 - +3%
Voc and Isc tolerance	±3%
Fire rating	Class C (UL 790)
Protection class	Class II (IEC 61140)
Mechanical loads	Front load 5400 Pa, Back load 2400 Pa

Corporate and product certificates	
ECOVADIS rating - Platinum medal (TOP 1%)	
Solar Industry Forced Labor Prevention Pledge by SEIA	
ISO9001:2015 - Quality Management Systems	
ISO14001:2015 - Environmental Management System	
WEEE compliance in Germany	
PV CYCLE Italy	
IEC 61215 - Terrestrial photovoltaic (PV) modules - Design qualification and type approval	
IEC 61730 - Photovoltaic (PV) module safety qualification	
IEC 61701 - Photovoltaic (PV) modules - Salt mist corrosion testing	
IEC 62716 - Photovoltaic (PV) modules - Ammonia corrosion testing	
IEC TS 62804 - Photovoltaic (PV) modules - Test methods for the detection of potential-induced degradation	
Hail resistance HW3/RG3	
Certificate of Factory Production Control (UK) - MCS	
Fire reaction class: 1 - LAPI	



NOTE: Read the safety and installation manual before using the product. This data sheet is not legally binding, Eurener reserves the right of final interpretation. Eurener reserves the right to change the product characteristics and/or specifications without prior notice. The latest versions of all documents can always be found on our website at [www.eurener.com](http://www.eurener.com).

**SINCE 1997**  
 more than energy

**eurener.com**  
 contact@eurenerworld.com  
 +34 960 045 515  
 Calle Colón, 1-23  
 46004, Valencia, Spain

**European Experts in Residential modules**

Since 1997 our main purpose has been to supply quality and long-lasting photovoltaic modules that allow us and future generations, to continue generating clean energy to take care of our planet.

**Icon PERC**

**> 375-380W**



- +20.8% Module efficiency**  
Module efficiency up to 20.87 %
- Different designs**  
Black - Silver - Bicolour
- PID resistance**  
Certified according to IEC TS 62804 standards
- Increased resistance**  
Certified resistance against salt mist and ammonia
- Hail resistance**  
RG3/HW3 certified
- Easy to handle**  
Comfortable installation thanks to an optimized area size

**20 Years**  
 Product Warranty  
 +5 years for Premium Partners

**30 Years**  
 Performance Warranty  
 Linear Warranty

**2%** First year degradation  
**0.62%** Annual degradation  
**80%** Power in year 30

**Light up your world with Eurener**

Eurener's extensive portfolio of certifications and awards is testament to our unwavering commitment to our partners and our deep sense of social and ethical responsibility.



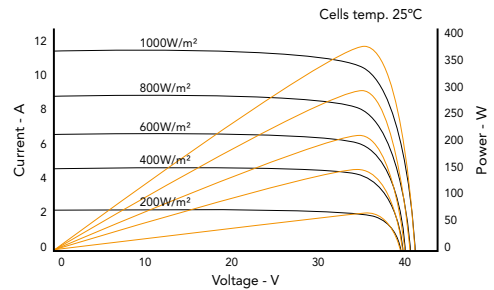
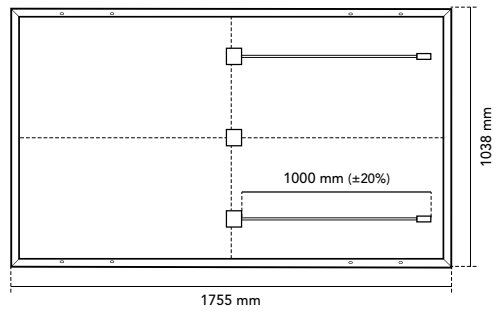

**Mechanical Specification**

Solar cells	Monocrystalline silicon cells
Front Glass	3.2 mm thick tempered glass with high strength and ARC
Frame	Black/silver anodized aluminium
Junction Box	IP68, 3 by-pass diodes
Connector	Connector MC4 compatible
Cable	1000 mm (±20%) length and 4 mm² section
Dimension	1755 x 1038 x 35 mm (±1%)
Area	1.82 m²
Weight	19.2 kg
Packaging	858 pcs/truck

**Temperature Coefficients**

Temperature coefficient of Isc (α)	0.041 %/°C
Temperature coefficient of Voc (β)	-0.295 %/°C
Temperature coefficient of Pmax (γ)	-0.37 %/°C
Temperature range	-40 °C ~ +85 °C
Nominal operating cell temperature (NOCT)	43 ± 3 °C

	MEPV 375	MEPV 380
<b>Electrical Characteristics STC</b>		
Nominal power. Pmax	375 Wp	380 Wp
Short-circuit current (Isc)	11.46 A	11.55 A
Open-circuit voltage (Voc)	41.50 V	41.70 V
Maximum power current (Imp)	10.95 A	11.03 A
Maximum power voltage (Vmp)	34.28 V	34.47 V
Module efficiency	20.61 %	20.87 %
<b>Electrical Characteristics NOCT</b>		
Nominal power. Pmax	283 Wp	287 Wp
Short-circuit current (Isc)	9.24 A	9.31 A
Open-circuit voltage (Voc)	39.30 V	39.49 V
Maximum power current (Imp)	8.83 A	8.89 A
Maximum power voltage (Vmp)	32.08 V	32.26 V

\* STC: 1000 W/m², module temperature 25°C, AM 1.5  
 \* NOCT: 800 W/m², ambient temperature 20°C, AM 1.5

**Operating parameters**

Maximum voltage	1000 - 1500 V
Maximum series fuse rating. Ir	20 A
Power output tolerance	0 - +3%
Voc and Isc tolerance	±3%
Fire rating	Class C (UL 790)
Protection class	Class II (IEC 61140)
Mechanical loads	Front load 5400 Pa, Back load 2400 Pa

**Corporate and product certificates**

ECOVADIS rating - Platinum medal (TOP 1%)
Solar Industry Forced Labor Prevention Pledge by SEIA
ISO9001:2015 - Quality Management Systems
ISO14001:2015 - Environmental Management System
WEEE compliance in Germany
PV CYCLE Italy
IEC 61215 - Terrestrial photovoltaic (PV) modules - Design qualification and type approval
IEC 61730 - Photovoltaic (PV) module safety qualification
IEC 61701 - Photovoltaic (PV) modules - Salt mist corrosion testing
IEC 62716 - Photovoltaic (PV) modules - Ammonia corrosion testing
IEC TS 62804 - Photovoltaic (PV) modules - Test methods for the detection of potential-induced degradation
Hail resistance HW3/RG3
Certificate of Factory Production Control (UK) - MCS
Fire reaction class: 1 - LAPI



NOTE: Read the safety and installation manual before using the product. This data sheet is not legally binding, Eurener reserves the right of final interpretation. Eurener reserves the right to change the product characteristics and/or specifications without prior notice. The latest versions of all documents can always be found on our website at [www.eurener.com](http://www.eurener.com).

**SINCE 1997**  
 more than energy

**eurener.com**  
 contact@eurenerworld.com  
 +34 960 045 515  
 Calle Colón, 1-23  
 46004, Valencia, Spain

**European Experts in Residential modules**

Since 1997 our main purpose has been to supply quality and long-lasting photovoltaic modules that allow us and future generations, to continue generating clean energy to take care of our planet.

**Icon PERC**

> **400-420W**



- +21.4% Module efficiency**  
Module efficiency up to 21.49 %
- Different designs**  
Black - Silver - Bicolour
- PID resistance**  
Certified according to IEC TS 62804 standards
- Increased resistance**  
Certified resistance against salt mist and ammonia
- Hail resistance**  
RG3/HW3 certified
- Easy to handle**  
Comfortable installation thanks to an optimized area size

**20 Years**  
 Product Warranty  
 +5 years for Premium Partners

**30 Years**  
 Performance Warranty  
 Linear Warranty

**2%** First year degradation  
**0.62%** Annual degradation  
**80%** Power in year 30

**Light up your world with Eurener**

Eurener's extensive portfolio of certifications and awards is testament to our unwavering commitment to our partners and our deep sense of social and ethical responsibility.





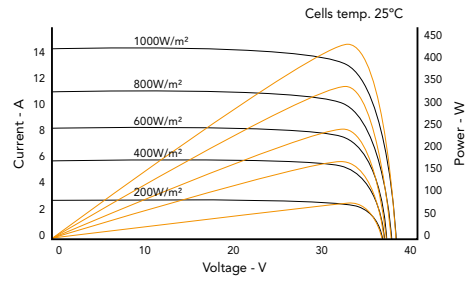
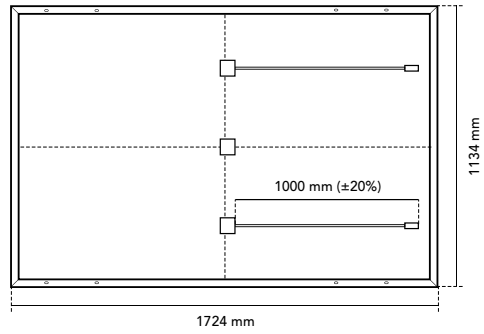

Mechanical Specification	
Solar cells	Monocrystalline silicon cells
Front Glass	3.2 mm thick tempered glass with high strength and ARC
Frame	Black/silver anodized aluminium
Junction Box	IP68, 3 by-pass diodes
Connector	Connector MC4 compatible
Cable	1000 mm (±20%) length and 4 mm <sup>2</sup> section
Dimension	1724 x 1134 x 30 mm (±1%)
Area	1.96 m <sup>2</sup>
Weight	21.5 kg
Packaging	962/936 pcs/truck

Temperature Coefficients	
Temperature coefficient of Isc (α)	0.044 %/°C
Temperature coefficient of Voc (β)	-0.276 %/°C
Temperature coefficient of Pmax (γ)	-0.35 %/°C
Temperature range	-40 °C ~ +85 °C
Nominal operating cell temperature (NOCT)	45 ± 2 °C

	MEPV 400	MEPV 410	MEPV 415	MEPV 420 SILVER ONLY
<b>Electrical Characteristics</b>				
STC				
Nominal power. Pmax	400 Wp	410 Wp	415 Wp	420 Wp
Short-circuit current (Isc)	13.79 A	13.95 A	14.02 A	14.10 A
Open-circuit voltage (Voc)	37.07 V	37.32 V	37.45 V	37.57 V
Maximum power current (Imp)	12.90 A	13.04 A	13.13 A	13.21 A
Maximum power voltage (Vmp)	31.01 V	31.45 V	31.61 V	31.81 V
Module efficiency	20.46 %	20.98 %	21.23 %	21.49 %
<b>Electrical Characteristics</b>				
NOCT				
Nominal power. Pmax	302 Wp	309 Wp	313 Wp	317 Wp
Short-circuit current (Isc)	11.13 A	11.26 A	11.31 A	11.38 A
Open-circuit voltage (Voc)	35.02 V	35.26 V	35.38 V	35.50 V
Maximum power current (Imp)	10.42 A	10.53 A	10.60 A	10.67 A
Maximum power voltage (Vmp)	28.96 V	29.39 V	29.54 V	29.74 V

\* STC: 1000 W/m<sup>2</sup>, module temperature 25°C, AM 1.5  
 \* NOCT: 800 W/m<sup>2</sup>, ambient temperature 20°C, AM 1.5

Operating parameters	
Maximum voltage	1000 - 1500 V
Maximum series fuse rating. Ir	25 A
Power output tolerance	0 - +3%
Voc and Isc tolerance	±3%
Fire rating	Class C. (UL 790)
Protection class	Class II (IEC 61140)
Mechanical loads	Front load 5400 Pa, Back load 2400 Pa

Corporate and product certificates	
ECOVDIS rating - Platinum medal (TOP 1%)	
Solar Industry Forced Labor Prevention Pledge by SEIA	
ISO9001:2015 - Quality Management Systems	
ISO14001:2015 - Environmental Management System	
WEEE compliance in Germany	
PV CYCLE Italy	
IEC 61215 - Terrestrial photovoltaic (PV) modules - Design qualification and type approval	
IEC 61730 - Photovoltaic (PV) module safety qualification	
IEC 61701 - Photovoltaic (PV) modules - Salt mist corrosion testing	
IEC 62716 - Photovoltaic (PV) modules - Ammonia corrosion testing	
IEC TS 62804 - Photovoltaic (PV) modules - Test methods for the detection of potential-induced degradation	
Hail resistance HW3/RG3	
Certificate of Factory Production Control (UK) - MCS	
Fire reaction class: 1 - LAPI	
Assessed by SundaHus	



NOTE: Read the safety and installation manual before using the product. This data sheet is not legally binding, Eurener reserves the right of final interpretation. Eurener reserves the right to change the product characteristics and/or specifications without prior notice. The latest versions of all documents can always be found on our website at [www.eurener.com](http://www.eurener.com).

**SINCE 1997**  
 more than energy

**eurener.com**  
 contact@eurenerworld.com  
 +34 960 045 515  
 Calle Colón, 1-23  
 46004, Valencia, Spain

**European Experts in Residential modules**

Since 1997 our main purpose has been to supply quality and long-lasting photovoltaic modules that allow us and future generations, to continue generating clean energy to take care of our planet.

## Icon Plus PERC

# > 450-460W

- +21.1% Module efficiency**  
Module efficiency up to 21.19%
- Different designs**  
Black - Silver - Bicolour
- PID resistance**  
Certified according to IEC TS 62804 standards
- Increased resistance**  
Certified resistance against salt mist and ammonia
- Hail resistance**  
RG3/HW3 certified
- Project versatility**  
For both residential and industrial roofs



**20 Years**  
 Product Warranty  
 +5 years for Premium Partners

**30 Years**  
 Performance Warranty  
 Linear Warranty

**2%** First year degradation  
**0.62%** Annual degradation  
**80%** Power in year 30

### Light up your world with Eurener

Eurener's extensive portfolio of certifications and awards is testament to our unwavering commitment to our partners and our deep sense of social and ethical responsibility.



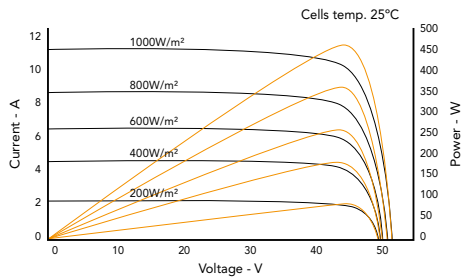
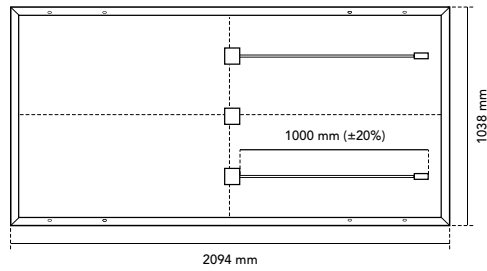

Mechanical Specification	
Solar cells	Monocrystalline silicon cells
Front Glass	3.2 mm thick tempered glass with high strength and ARC
Frame	Black/silver anodized aluminium
Junction Box	IP68, 3 by-pass diodes
Connector	Connector MC4 compatible
Cable	1000 mm (±20%) length and 4 mm² section
Dimension	2094 x 1038 x 35 mm (±1%)
Area	2.17 m²
Weight	25 kg
Packaging	726 pcs/truck

Temperature Coefficients	
Temperature coefficient of Isc (α)	0.046 %/°C
Temperature coefficient of Voc (β)	-0.276 %/°C
Temperature coefficient of Pmax (γ)	-0.381 %/°C
Temperature range	-40 °C ~ +85 °C
Nominal operating cell temperature (NOCT)	45 ± 2 °C

	MEPV 450	MEPV 460
<b>Electrical Characteristics STC</b>		
Nominal power, Pmax	450 Wp	460 Wp
Short-circuit current (Isc)	11.50 A	11.66 A
Open-circuit voltage (Voc)	49.98 V	50.38 V
Maximum power current (Imp)	10.89 A	11.03 A
Maximum power voltage (Vmp)	41.36 V	41.76 V
Module efficiency	20.72 %	21.19 %
<b>Electrical Characteristics NOCT</b>		
Nominal power, Pmax	339 Wp	350 Wp
Short-circuit current (Isc)	9.26 A	9.37 A
Open-circuit voltage (Voc)	47.18 V	47.52 V
Maximum power current (Imp)	8.71 A	8.88 A
Maximum power voltage (Vmp)	38.88 V	39.39 V

\* STC: 1000 W/m², module temperature 25°C, AM 1.5  
 \* NOCT: 800 W/m², ambient temperature 20°C, AM 1.5

Operating parameters	
Maximum voltage	1000 - 1500 V
Maximum series fuse rating, Ir	20 A
Power output tolerance	0 - +3%
Voc and Isc tolerance	±3%
Fire rating	Class C (UL 790)
Protection class	Class II (IEC 61140)
Mechanical loads	Front load 5400 Pa, Back load 2400 Pa

Corporate and product certificates	
ECOVADIS rating - Platinum medal (TOP 1%)	
Solar Industry Forced Labor Prevention Pledge by SEIA	
ISO9001:2015 - Quality Management Systems	
ISO14001:2015 - Environmental Management System	
WEEE compliance in Germany	
PV CYCLE Italy	
IEC 61215 - Terrestrial photovoltaic (PV) modules - Design qualification and type approval	
IEC 61730 - Photovoltaic (PV) module safety qualification	
IEC 61701 - Photovoltaic (PV) modules - Salt mist corrosion testing	
IEC 62716 - Photovoltaic (PV) modules - Ammonia corrosion testing	
IEC TS 62804 - Photovoltaic (PV) modules - Test methods for the detection of potential-induced degradation	
Hail resistance HW3/RG3	
Certificate of Factory Production Control (UK) - MCS	
Fire reaction class: 1 - LAPI	
Assessed by Sundahus	



NOTE: Read the safety and installation manual before using the product. This data sheet is not legally binding, Eurener reserves the right of final interpretation. Eurener reserves the right to change the product characteristics and/or specifications without prior notice. The latest versions of all documents can always be found on our website at [www.eurener.com](http://www.eurener.com).

**SINCE 1997**  
 more than energy

**eurener.com**  
 contact@eurenerworld.com  
 +34 960 045 515  
 Calle Colón, 1-23  
 46004, Valencia, Spain

**European Experts in Residential modules**

Since 1997 our main purpose has been to supply quality and long-lasting photovoltaic modules that allow us and future generations, to continue generating clean energy to take care of our planet.

## Icon Plus PERC

# > 500W



- +21%** **Module efficiency**  
Module efficiency up to 21.06 %
- Different designs**  
Black - Silver - Bicolour
- PID resistance**  
Certified according to IEC TS 62804 standards
- Increased resistance**  
Certified resistance against salt mist and ammonia
- Hail resistance**  
RG3/HW3 certified
- Project versatility**  
For both residential and industrial roofs

**20 Years**  
 Product Warranty  
 +5 years for Premium Partners

**30 Years**  
 Performance Warranty  
 Linear Warranty

**2%** First year degradation  
**0.62%** Annual degradation  
**80%** Power in year 30

### Light up your world with Eurener

Eurener's extensive portfolio of certifications and awards is testament to our unwavering commitment to our partners and our deep sense of social and ethical responsibility.



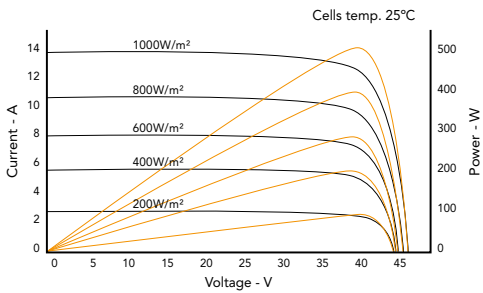
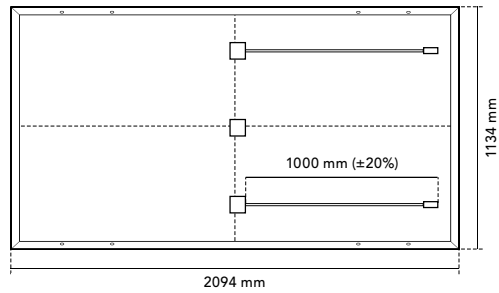

Mechanical Specification	
Solar cells	Monocrystalline silicon cells
Front Glass	3.2 mm thick tempered glass with high strength and ARC
Frame	Black/silver anodized aluminium
Junction Box	IP68, 3 by-pass diodes
Connector	Connector MC4 compatible
Cable	1000 mm (±20%) length and 4 mm <sup>2</sup> section
Dimension and packaging	2094 x 1134 x 30 mm (±1%) > 792 pcs/truck 2094 x 1134 x 35 mm (±1%) > 682 pcs/truck
Area	2.37 m <sup>2</sup>
Weight	26.3 kg

Temperature Coefficients	
Temperature coefficient of Isc (α)	0.0445 %/°C
Temperature coefficient of Voc (β)	-0.275 %/°C
Temperature coefficient of Pmax (γ)	-0.35 %/°C
Temperature range	-40 °C ~ +85 °C
Nominal operating cell temperature (NOCT)	45 ± 2 °C

	MEPV 500
<b>Electrical Characteristics</b>	
	STC
Nominal power, Pmax	500 Wp
Short-circuit current (Isc)	13.93 A
Open-circuit voltage (Voc)	45.59 V
Maximum power current (Imp)	13.04 A
Maximum power voltage (Vmp)	38.35 V
Module efficiency	21.06 %
<b>Electrical Characteristics</b>	
	NOCT
Nominal power, Pmax	378 Wp
Short-circuit current (Isc)	11.24 A
Open-circuit voltage (Voc)	43.08 V
Maximum power current (Imp)	10.53 A
Maximum power voltage (Vmp)	35.84 V

\* STC: 1000 W/m<sup>2</sup>, module temperature 25°C, AM 1.5  
\* NOCT: 800 W/m<sup>2</sup>, ambient temperature 20°C, AM 1.5

Operating parameters	
Maximum voltage	1000 - 1500 V
Maximum series fuse rating, Ir	25 A
Power output tolerance	0 - +3%
Voc and Isc tolerance	±3%
Fire rating	Class C (UL 790)
Protection class	Class II (IEC 61140)
Mechanical loads	Front load 5400 Pa, Back load 2400 Pa

Corporate and product certificates	
ECOVADIS rating - Platinum medal (TOP 1%)	
Solar Industry Forced Labor Prevention Pledge by SEIA	
ISO9001:2015 - Quality Management Systems	
ISO14001:2015 - Environmental Management System	
WEEE compliance in Germany	
PV CYCLE Italy	
IEC 61215 - Terrestrial photovoltaic (PV) modules - Design qualification and type approval	
IEC 61730 - Photovoltaic (PV) module safety qualification	
IEC 61701 - Photovoltaic (PV) modules - Salt mist corrosion testing	
IEC 62716 - Photovoltaic (PV) modules - Ammonia corrosion testing	
IEC TS 62804 - Photovoltaic (PV) modules - Test methods for the detection of potential-induced degradation	
Hail resistance HW3/RG3	
Certificate of Factory Production Control (UK) - MCS	
Fire reaction class: 1 - LAPI	



NOTE: Read the safety and installation manual before using the product. This data sheet is not legally binding, Eurener reserves the right of final interpretation. Eurener reserves the right to change the product characteristics and/or specifications without prior notice. The latest versions of all documents can always be found on our website at [www.eurener.com](http://www.eurener.com).

**SINCE 1997**  
more than energy

**eurener.com**  
contact@eurenerworld.com  
+34 960 045 515  
Calle Colón, 1-23  
46004, Valencia, Spain

**European Experts in Residential modules**

Since 1997 our main purpose has been to supply quality and long-lasting photovoltaic modules that allow us and future generations, to continue generating clean energy to take care of our planet.

**Icon Plus PERC**  
**> 550W**



- +20.3% Module efficiency**  
Module efficiency up to 21.30 %
- PID resistance**  
Certified according to IEC TS 62804 standards
- Increased resistance**  
Certified resistance against salt mist and ammonia
- Hail resistance**  
RG3/HW3 certified
- Increased PV surface**  
Higher power output for commercial and ground projects
- Optimized BOS**  
Lower structure, materials and wiring costs

**20 Years**  
Product Warranty  
+5 years for Premium Partners

**30 Years**  
Performance Warranty  
Linear Warranty

**2%** First year degradation  
**0.62%** Annual degradation  
**80%** Power in year 30

**Light up your world with Eurener**

Eurener's extensive portfolio of certifications and awards is testament to our unwavering commitment to our partners and our deep sense of social and ethical responsibility.





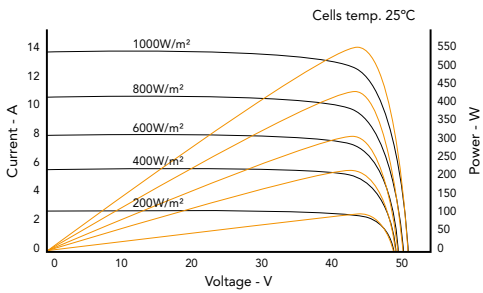
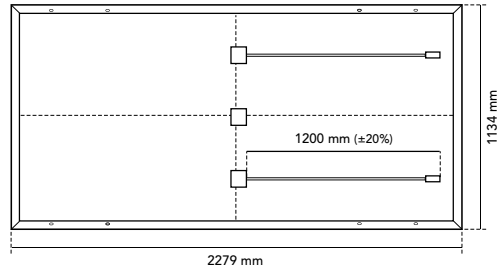

**Mechanical Specification**

Solar cells	Monocrystalline silicon cells
Front Glass	3.2 mm thick tempered glass with high strength and ARC
Frame	Silver anodized aluminium
Junction Box	IP68, 3 by-pass diodes
Connector	Connector MC4 compatible
Cable	1200 mm (±20%) length and 4 mm² section
Dimension	2279 x 1134 x 35 mm (±1%)
Area	2.58 m²
Weight	28 kg
Packaging	620 pcs/truck

**Temperature Coefficients**

Temperature coefficient of Isc (α)	0.045 %/°C
Temperature coefficient of Voc (β)	-0.275 %/°C
Temperature coefficient of Pmax (γ)	-0.35 %/°C
Temperature range	-40 °C ~ +85 °C
Nominal operating cell temperature (NOCT)	43 ± 2 °C

**MEPV 550**

Electrical Characteristics	STC
Nominal power. Pmax	550 Wp
Short-circuit current (Isc)	13.96 A
Open-circuit voltage (Voc)	49.85 V
Maximum power current (Imp)	13.19 A
Maximum power voltage (Vmp)	41.72 V
Module efficiency	21.30 %
Electrical Characteristics	NOCT
Nominal power. Pmax	416 Wp
Short-circuit current (Isc)	11.16 A
Open-circuit voltage (Voc)	47.12 V
Maximum power current (Imp)	10.59 A
Maximum power voltage (Vmp)	39.28 V

\* STC: 1000 W/m², module temperature 25°C, AM 1.5  
 \* NOCT: 800 W/m², ambient temperature 20°C, AM 1.5

**Operating parameters**

Maximum voltage	1000 - 1500 V
Maximum series fuse rating. Ir	25 A
Power output tolerance	0 - +3%
Voc and Isc tolerance	±3%
Fire rating	Class C (UL 790)
Protection class	Class II (IEC 61140)
Mechanical loads	Front load 5400 Pa, Back load 2400 Pa

**Corporate and product certificates**

ECOVADIS rating - Platinum medal (TOP 1%)
Solar Industry Forced Labor Prevention Pledge by SEIA
ISO9001:2015 - Quality Management Systems
ISO14001:2015 - Environmental Management System
WEEE compliance in Germany
PV CYCLE Italy
IEC 61215 - Terrestrial photovoltaic (PV) modules - Design qualification and type approval
IEC 61730 - Photovoltaic (PV) module safety qualification
IEC 61701 - Photovoltaic (PV) modules - Salt mist corrosion testing
IEC 62716 - Photovoltaic (PV) modules - Ammonia corrosion testing
IEC TS 62804 - Photovoltaic (PV) modules - Test methods for the detection of potential-induced degradation
Hail resistance HW3/RG3
Certificate of Factory Production Control (UK) - MCS
Fire reaction class: 1 - LAPI



NOTE: Read the safety and installation manual before using the product. This data sheet is not legally binding, Eurener reserves the right of final interpretation. Eurener reserves the right to change the product characteristics and/or specifications without prior notice. The latest versions of all documents can always be found on our website at [www.eurener.com](http://www.eurener.com).

**SINCE 1997**  
 more than energy

**eurener.com**  
 contact@eurenerworld.com  
 +34 960 045 515  
 Calle Colón, 1-23  
 46004, Valencia. Spain

**European Experts in Residential modules**

Since 1997 our main purpose has been to supply quality and long-lasting photovoltaic modules that allow us and future generations, to continue generating clean energy to take care of our planet.

**Icon Plus PERC**

FRONT SIDE  
**550W**

› Double Glass Bifacial



**+21.3%**

**Module efficiency**  
 Module efficiency up to 21.30 %

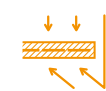

**Bifacial cell**  
 Extra energy generated from the backside of the cell depending on albedo



**Fire rating**  
 Class A



**Sustainable product**  
 High percentage of recyclable materials



**Increased PV surface**  
 Higher power output for commercial and ground projects



**Optimized BOS**  
 Lower structure, materials and wiring costs

**25 Years**

**Product Warranty**  
 +5 years for Premium Partners

**30 Years**

**Performance Warranty**  
 Linear Warranty

**2%** First year degradation  
**0.62%** Annual degradation  
**80%** Power in year 30

**Light up your world with Eurener**

Eurener's extensive portfolio of certifications and awards is testament to our unwavering commitment to our partners and our deep sense of social and ethical responsibility.





# Eurener MEPV — ICON Plus Double Glass Bifacial 550W

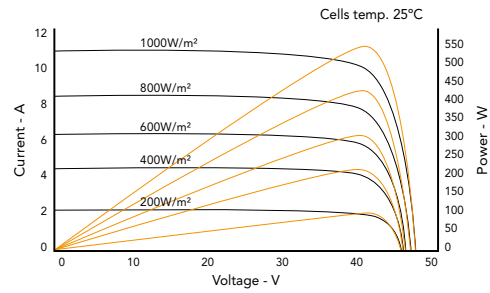
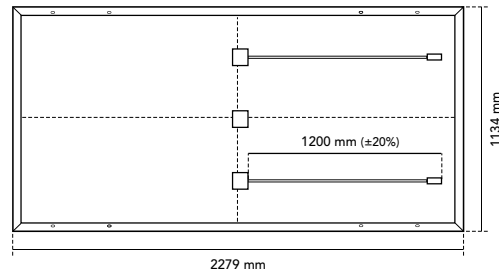

### Mechanical Specification

Solar cells	Bifacial monocrystalline silicon cells
Front Glass	2mm anti-reflective surface tempered solar glass
Back Glass	2mm tempered solar glass
Frame	Silver anodized aluminium
Junction Box	IP68, 3 by-pass diodes
Connector	Connector MC4 compatible
Cable	1200 mm (±20%) length and 4 mm² section
Dimension	2279 x 1134 x 35 mm (±1%)
Area	2.58 m²
Weight	33 kg
Packaging	620 pcs/truck

### Temperature Coefficients

Temperature coefficient of Isc (α)	0.045 %/°C
Temperature coefficient of Voc (β)	-0.275 %/°C
Temperature coefficient of Pmax (γ)	-0.35 %/°C
Temperature range	-40 °C ~ +85 °C
Nominal operating cell temperature (NOCT)	43 ± 2 °C

### MEPV 550

Electrical Characteristics	STC	NOCT
Nominal power. Pmax	550 Wp	416 Wp
Short-circuit current (Isc)	13.96 A	11.16 A
Open-circuit voltage (Voc)	49.85 V	47.12 V
Maximum power current (Imp)	13.19 A	10.59 A
Maximum power voltage (Vmp)	41.72 V	39.28 V
Module efficiency	21.30 %	

Electrical Characteristics	Bifacial gain 10%
Nominal power. Pmax	605 Wp
Short-circuit current (Isc)	15.35 A
Open-circuit voltage (Voc)	49.85 V
Maximum power current (Imp)	14.50 A
Maximum power voltage (Vmp)	41.72 V

\* STC: 1000 W/m², module temperature 25°C, AM 1.5  
 \* NOCT: 800 W/m², ambient temperature 20°C, AM 1.5

Operating parameters	
Maximum voltage	1500 V
Maximum series fuse rating. Ir	20 A
Power output tolerance	0 - +3%
Voc and Isc tolerance	±3%
Fire rating	Class A (UL 790)
Protection class	Class II (IEC 61140)
Mechanical loads	Front load 5400 Pa, Back load 2400 Pa

### Corporate and product certificates

- ECOVADIS rating - Platinum medal (TOP 1%)
- Solar Industry Forced Labor Prevention Pledge by SEIA
- ISO9001:2015 - Quality Management Systems
- ISO14001:2015 - Environmental Management System
- WEEE compliance in Germany
- PV CYCLE Italy
- IEC 61215 - Terrestrial photovoltaic (PV) modules - Design qualification and type approval
- IEC 61730 - Photovoltaic (PV) module safety qualification
- IEC 61701 - Photovoltaic (PV) modules - Salt mist corrosion testing
- IEC 62716 - Photovoltaic (PV) modules - Ammonia corrosion testing
- IEC TS 62804 - Photovoltaic (PV) modules - Test methods for the detection of potential-induced degradation
- Hail resistance HW3/RG3
- Certificate of Factory Production Control (UK) - MCS
- Fire reaction class: 1 - LAPI



NOTE: Read the safety and installation manual before using the product. This data sheet is not legally binding, Eurener reserves the right of final interpretation. Eurener reserves the right to change the product characteristics and/or specifications without prior notice. The latest versions of all documents can always be found on our website at [www.eurener.com](http://www.eurener.com).

**SINCE 1997**  
 more than energy

**eurener.com**  
 contact@eurenerworld.com  
 +34 960 045 515  
 Calle Colón, 1-23  
 46004, Valencia, Spain

**European Experts in Residential modules**

Since 1997 our main purpose has been to supply quality and long-lasting photovoltaic modules that allow us and future generations, to continue generating clean energy to take care of our planet.







## MEPV AGRO Series

↳ *Solar innovation for agrovoltatics and beyond.*

Harvest the sun's brightness with our versatile solar panels for agrovoltatics, carports, and resilient greenhouses.

## AGRO — PERC TECHNOLOGY

› *from 260 to 365W*



### High transparency

A special cell disposition allows a high percentage of light to pass through the module.



### Wide variety of applications

Perfect for integration in greenhouses and agrovoltaic applications.

Also suitable for carports or other types of roofs.



### Bifacial cells

Bifaciality grants the possibility of increasing the power output thanks to the production from the rear side of the cells depending on albedo.



### Fire rating

Class A according to UL 790 standard.



### Hail resistance RG3/HW3

Certified resistance against hail impacts of 30 mm diameter at 23.9 m/s.



### Sustainability

Resistant and long-lasting modules with high percentage of recyclable materials.

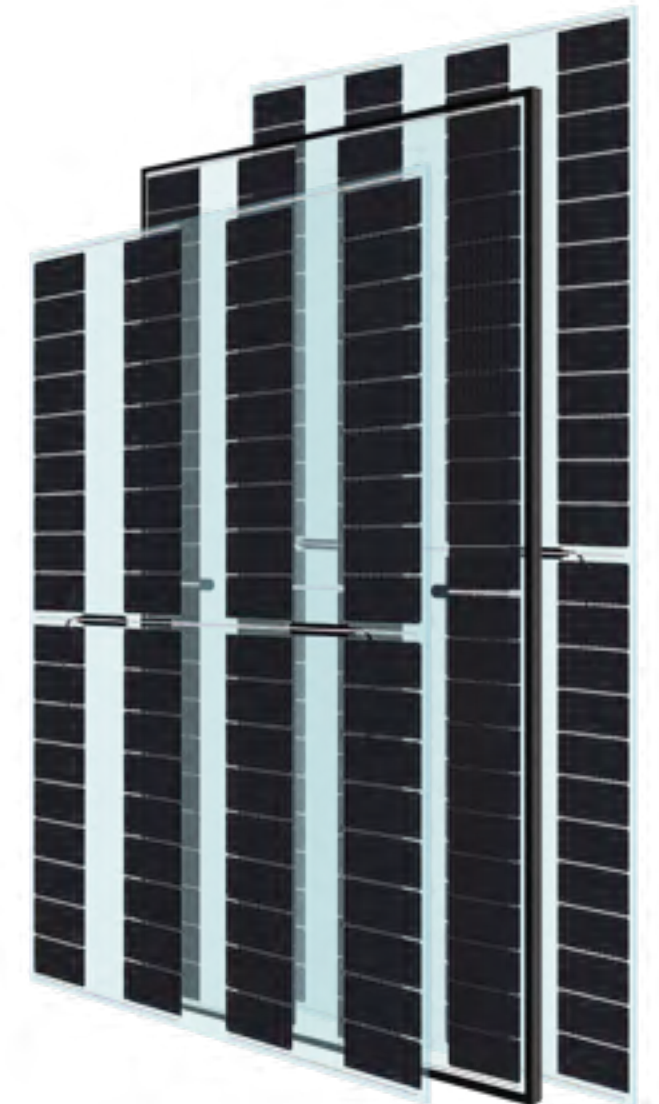





## MEPV Agro Series

### DATA SHEETS

- › Eurener MEPV Agro DG Bif 260-275W  
*pag. 61/62*
- › Eurener MEPV Agro DG Bif 325-335W  
*pag. 63/64*
- › Eurener MEPV Agro DG Bif 345-365W  
*pag. 65/66*



European Experts  
in Residential Modules

## Agro PERC

FRONT SIDE

# 260 - 275 W

› Double Glass Bifacial



### Module efficiency

Module efficiency up to 14.20 %



### 45% Transmittance

High percentage of light can pass through it



### Versatility

For greenhouses, carports or other roofs

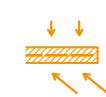

### Bifacial cell

Extra energy generated from the backside of the cell depending on albedo



### Fire rating

Class A



### Hail resistance

RG3/HW3 certified

# 25

Years

Product Warranty

+5 years for Premium Partners

# 30

Years

Performance Warranty

Linear Warranty

2% First year degradation

0.55% Annual degradation

82.05% Power in year 30

### Light up your world with Eurener

Eurener's extensive portfolio of certifications and awards is testament to our unwavering commitment to our partners and our deep sense of social and ethical responsibility.





# Eurener MEPV — AGRO Double Glass Bifacial 260-275W

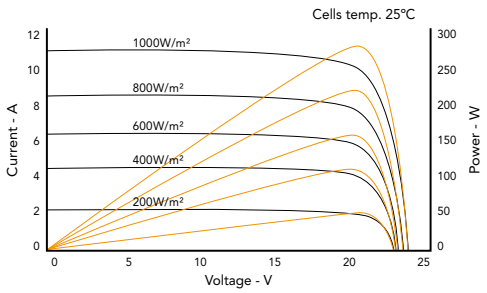
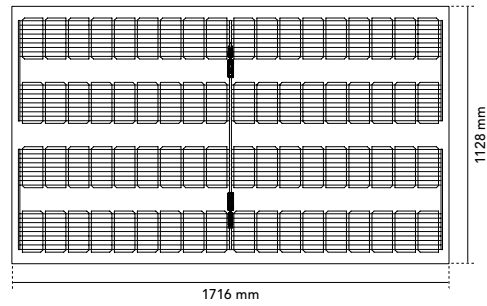

Mechanical Specification	
Solar cells	Bifacial monocrystalline silicon cells
Front Glass	2mm anti-reflective surface tempered solar glass
Back Glass	2mm tempered solar glass
Frame	Frameless
Junction Box	IP68, 3 by-pass diodes
Connector	Connector MC4 compatible
Cable	1000 mm (±20%) length and 4 mm² section
Dimension	1716 x 1128 mm (±1%)
Area	1.94 m²
Weight	25.5 kg

Temperature Coefficients	
Temperature coefficient of Isc (α)	0.04 %/°C
Temperature coefficient of Voc (β)	-0.28 %/°C
Temperature coefficient of Pmax (γ)	-0.35 %/°C
Temperature range	-40 °C ~ +85 °C
Nominal operating cell temperature (NOCT)	43 ± 2 °C

	MEPV 260		MEPV 265		MEPV 270		MEPV 275	
Electrical Characteristics	STC	NOCT	STC	NOCT	STC	NOCT	STC	NOCT
Nominal power. Pmax	260 Wp	194 Wp	265 Wp	198 Wp	270 Wp	201 Wp	275 Wp	205 Wp
Short-circuit current (Isc)	13.54 A	10.92 A	13.64 A	11.02 A	13.75 A	11.09 A	13.84 A	11.18 A
Open-circuit voltage (Voc)	24.21 V	22.90 V	24.39 V	23.12 V	24.69 V	23.26 V	24.96 V	23.53 V
Maximum power current (Imp)	12.95 A	10.27 A	13.06 A	10.39 A	13.15 A	10.43 A	13.19 A	10.50 A
Maximum power voltage (Vmp)	20.11 V	18.90 V	20.32 V	19.03 V	20.55 V	19.29 V	20.86 V	19.50 V
Module efficiency	13.45 %		13.71 %		13.96 %		14.20 %	

Electrical Characteristics	Bifacial gain 10%			
Nominal power. Pmax	286 Wp	292 Wp	297 Wp	302 Wp
Short-circuit current (Isc)	14.90 A	15.00 A	15.12 A	15.22 A
Open-circuit voltage (Voc)	24.21 V	24.39 V	24.69 V	24.96 V
Maximum power current (Imp)	14.22 A	14.35 A	14.45 A	14.50 A
Maximum power voltage (Vmp)	20.11 V	20.32 V	20.55 V	20.86 V

\* STC: 1000 W/m², module temperature 25°C, AM 1.5  
 \* NOCT: 800 W/m², ambient temperature 20°C, AM 1.5

Operating parameters	
Maximum voltage	1500 V
Maximum series fuse rating. Ir	30 A
Power output tolerance	0 - +3%
Voc and Isc tolerance	±3%
Fire rating	Class A (UL 790)
Protection class	Class II (IEC 61140)
Mechanical loads	Front load 5400 Pa, Back load 2400 Pa

Corporate and product certificates	
ECOVADIS rating - Platinum medal (TOP 1%)	
Solar Industry Forced Labor Prevention Pledge by SEIA	
ISO9001:2015 - Quality Management Systems	
ISO14001:2015 - Environmental Management System	
WEEE compliance in Germany	
PV CYCLE Italy	
IEC 61215 - Terrestrial photovoltaic (PV) modules - Design qualification and type approval	
IEC 61730 - Photovoltaic (PV) module safety qualification	
IEC 61701 - Photovoltaic (PV) modules - Salt mist corrosion testing	
IEC 62716 - Photovoltaic (PV) modules - Ammonia corrosion testing	
IEC TS 62804 - Photovoltaic (PV) modules - Test methods for the detection of potential-induced degradation	
Hail resistance HW3/RG3	
Certificate of Factory Production Control (UK) - MCS	
Fire reaction class: 1 - LAPI	



NOTE: Read the safety and installation manual before using the product. This data sheet is not legally binding, Eurener reserves the right of final interpretation. Eurener reserves the right to change the product characteristics and/or specifications without prior notice. The latest versions of all documents can always be found on our website at [www.eurener.com](http://www.eurener.com).

**SINCE 1997**  
 more than energy

**eurener.com**  
 contact@eurenerworld.com  
 +34 960 045 515  
 Calle Colón, 1-23  
 46004, Valencia, Spain

**European Experts in Residential modules**

Since 1997 our main purpose has been to supply quality and long-lasting photovoltaic modules that allow us and future generations, to continue generating clean energy to take care of our planet.



European Experts  
 in Residential Modules

## Agro PERC

FRONT SIDE  
**325 - 335 W**

> Double Glass Bifacial



**Module efficiency**  
 Module efficiency up to 14.15 %



**36% Transmittance**  
 High percentage of light can pass through it



**Versatility**  
 For greenhouses, carports or other roofs

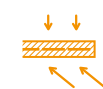

**Bifacial cell**  
 Extra energy generated from the backside of the cell depending on albedo



**Fire rating**  
 Class A



**Hail resistance**  
 RG3/HW3 certified



**25 Years**

**Product Warranty**  
 +5 years for Premium Partners

**30 Years**

**Performance Warranty**  
 Linear Warranty

**2% First year degradation**  
**0.55% Annual degradation**  
**82.05% Power in year 30**

### Light up your world with Eurener

Eurener's extensive portfolio of certifications and awards is testament to our unwavering commitment to our partners and our deep sense of social and ethical responsibility.







# Eurener MEPV — AGRO Double Glass Bifacial 325-335W

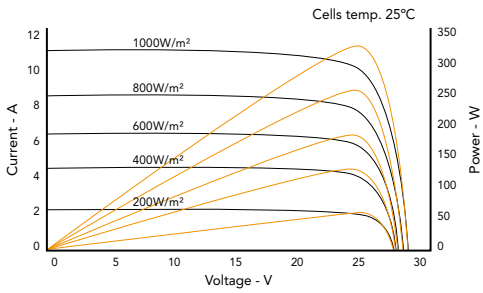
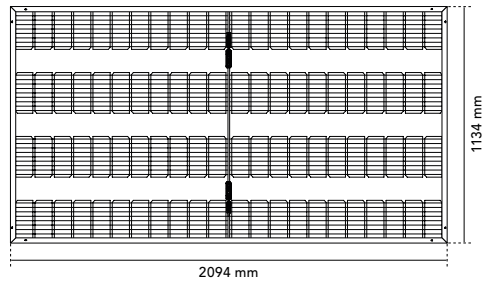

### Mechanical Specification

Solar cells	Bifacial monocrystalline silicon cells
Front Glass	2mm anti-reflective surface tempered solar glass
Back Glass	2mm tempered solar glass
Frame	Black anodized aluminium
Junction Box	IP68, 3 by-pass diodes
Connector	Connector MC4 compatible
Cable	1200 mm (±20%) length and 4 mm² section
Dimension	2094 x 1134 x 30 mm (±1%)
Area	2.37 m²
Weight	30 kg
Packaging	792 pcs/truck

### Temperature Coefficients

Temperature coefficient of Isc (α)	0.04 %/°C
Temperature coefficient of Voc (β)	-0.28 %/°C
Temperature coefficient of Pmax (γ)	-0.35 %/°C
Temperature range	-40 °C ~ +85 °C
Nominal operating cell temperature (NOCT)	43 ± 2 °C

Electrical Characteristics	MEPV 325		MEPV 330		MEPV 335	
	STC	NOCT	STC	NOCT	STC	NOCT
Nominal power. Pmax	325 Wp	247 Wp	330 Wp	251 Wp	335 Wp	255 Wp
Short-circuit current (Isc)	13.54 A	10.96 A	13.76 A	11.14 A	13.93 A	11.31 A
Open-circuit voltage (Voc)	30.31 V	28.77 V	30.47 V	28.96 V	30.68 V	29.13 V
Maximum power current (Imp)	12.88 A	10.45 A	12.97 A	10.53 A	13.13 A	10.62 A
Maximum power voltage (Vmp)	25.26 V	23.70 V	25.46 V	23.87 V	25.55 V	24.05 V
Module efficiency	13.67 %		13.93%		14.15%	

Electrical Characteristics	Bifacial gain 10%		
	MEPV 325	MEPV 330	MEPV 335
Nominal power. Pmax	358 Wp	363 Wp	369 Wp
Short-circuit current (Isc)	14.89 A	15.14 A	15.32 A
Open-circuit voltage (Voc)	30.31 V	30.47 V	30.68 V
Maximum power current (Imp)	14.15 A	14.26 A	14.42 A
Maximum power voltage (Vmp)	25.26 V	25.46 V	25.55 V

\* STC: 1000 W/m², module temperature 25°C, AM 1.5  
 \* NOCT: 800 W/m², ambient temperature 20°C, AM 1.5

Operating parameters	
Maximum voltage	1500 V
Maximum series fuse rating. Ir	30 A
Power output tolerance	0 - +3%
Voc and Isc tolerance	±3%
Fire rating	Class A (UL 790)
Protection class	Class II (IEC 61140)
Mechanical loads	Front load 5400 Pa, Back load 2400 Pa

### Corporate and product certificates

ECOVADIS rating - Platinum medal (TOP 1%)
Solar Industry Forced Labor Prevention Pledge by SEIA
ISO9001:2015 - Quality Management Systems
ISO14001:2015 - Environmental Management System
WEEE compliance in Germany
PV CYCLE Italy
IEC 61215 - Terrestrial photovoltaic (PV) modules - Design qualification and type approval
IEC 61730 - Photovoltaic (PV) module safety qualification
IEC 61701 - Photovoltaic (PV) modules - Salt mist corrosion testing
IEC 62716 - Photovoltaic (PV) modules - Ammonia corrosion testing
IEC TS 62804 - Photovoltaic (PV) modules - Test methods for the detection of potential-induced degradation
Hail resistance HW3/RG3
Certificate of Factory Production Control (UK) - MCS
Fire reaction class: 1 - LAPI



NOTE: Read the safety and installation manual before using the product. This data sheet is not legally binding, Eurener reserves the right of final interpretation. Eurener reserves the right to change the product characteristics and/or specifications without prior notice. The latest versions of all documents can always be found on our website at [www.eurener.com](http://www.eurener.com).

**SINCE 1997**  
 more than energy

**eurener.com**  
 contact@eurenerworld.com  
 +34 960 045 515  
 Calle Colón, 1-23  
 46004, Valencia, Spain

**European Experts in Residential modules**

Since 1997 our main purpose has been to supply quality and long-lasting photovoltaic modules that allow us and future generations, to continue generating clean energy to take care of our planet.



European Experts  
 in Residential Modules

## Agro PERC

FRONT SIDE  
**345 - 365 W**

› Double Glass Bifacial



**Module efficiency**  
 Module efficiency up to 14.24 %



**30% Transmittance**  
 High percentage of light can pass through it



**Versatility**  
 For greenhouses, carports or other roofs

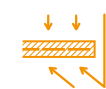

**Bifacial cell**  
 Extra energy generated from the backside of the cell depending on albedo



**Fire rating**  
 Class A



**Hail resistance**  
 RG3/HW3 certified

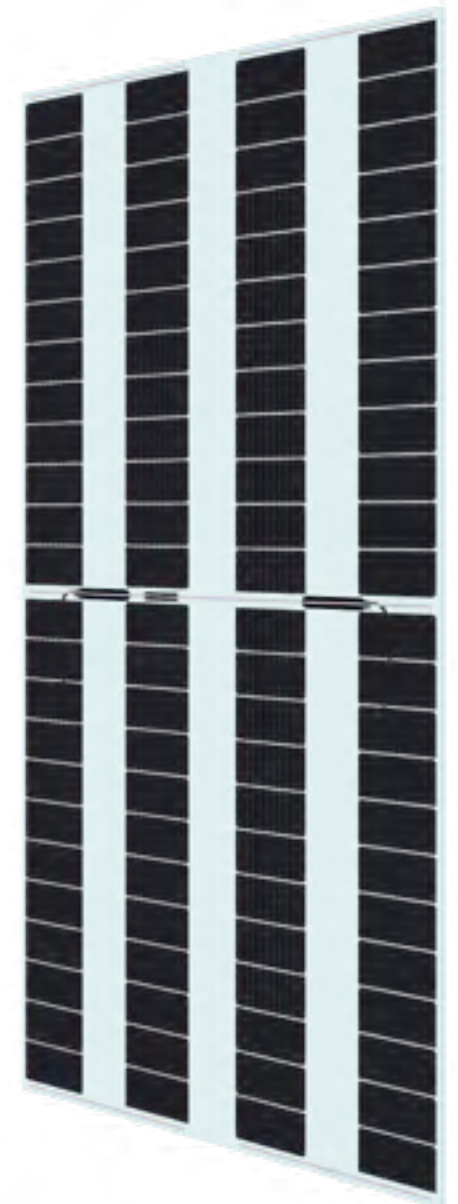

**25 Years**  
 Product Warranty  
 +5 years for Premium Partners

**30 Years**  
 Performance Warranty  
 Linear Warranty

**2%** First year degradation  
**0.55%** Annual degradation  
**82.05%** Power in year 30

### Light up your world with Eurener

Eurener's extensive portfolio of certifications and awards is testament to our unwavering commitment to our partners and our deep sense of social and ethical responsibility.





## Eurener MEPV — AGRO Double Glass Bifacial 345-365W

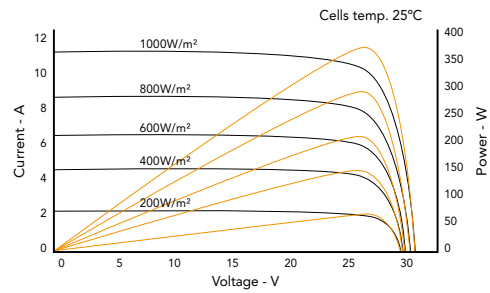
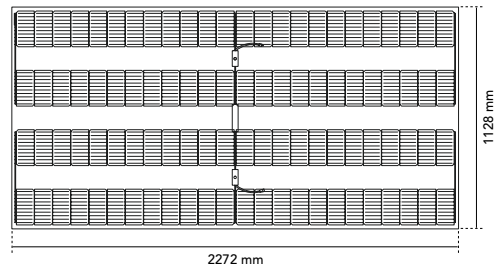

Mechanical Specification	
Solar cells	Bifacial monocrystalline silicon cells
Front Glass	2mm anti-reflective surface tempered solar glass
Back Glass	2mm tempered solar glass
Frame	Frameless
Junction Box	IP68, 3 by-pass diodes
Connector	Connector MC4 compatible
Cable	1200 mm (±20%) length and 4 mm <sup>2</sup> section
Dimension	2272 x 1128 mm (±1%)
Area	2.56 m <sup>2</sup>
Weight	26.8 kg

Temperature Coefficients	
Temperature coefficient of Isc (α)	0.04 %/°C
Temperature coefficient of Voc (β)	-0.28 %/°C
Temperature coefficient of Pmax (γ)	-0.35 %/°C
Temperature range	-40 °C ~ +85 °C
Nominal operating cell temperature (NOCT)	43 ± 2 °C

Electrical Characteristics	MEPV 345		MEPV 350		MEPV 355		MEPV 360		MEPV 365	
	STC	NOCT	STC	NOCT	STC	NOCT	STC	NOCT	STC	NOCT
Nominal power, Pmax	345 Wp	257 Wp	350 Wp	261 Wp	355 Wp	265 Wp	360 Wp	268 Wp	365 Wp	272 Wp
Short-circuit current (Isc)	13.74 A	11.10 A	13.90 A	11.21 A	13.97 A	11.27 A	14.01 A	11.32 A	14.07 A	11.36 A
Open-circuit voltage (Voc)	31.87 V	29.95 V	32.05 V	30.27 V	32.39 V	30.38 V	32.59 V	30.67 V	32.80 V	30.98 V
Maximum power current (Imp)	12.88 A	10.34 A	12.96 A	10.40 A	13.07 A	10.45 A	13.15 A	10.53 A	13.20 A	10.59 A
Maximum power voltage (Vmp)	26.80 V	24.85 V	27.02 V	25.05 V	27.18 V	25.37 V	27.39 V	25.43 V	27.68 V	25.76 V
Module efficiency	13.46 %		13.66 %		13.85 %		14.05 %		14.24 %	

  

Electrical Characteristics	Bifacial gain 10%				
Nominal power, Pmax	380 Wp	385 Wp	391 Wp	396 Wp	402 Wp
Short-circuit current (Isc)	15.11 A	15.29 A	15.36 A	15.41 A	15.48 A
Open-circuit voltage (Voc)	31.87 V	32.05 V	32.39 V	32.59 V	32.80 V
Maximum power current (Imp)	14.16 A	14.25 A	14.37 A	14.46 A	14.51 A
Maximum power voltage (Vmp)	26.80 V	27.02 V	27.18 V	27.39 V	27.68 V

\* STC: 1000 W/m<sup>2</sup>, module temperature 25°C, AM 1.5  
 \* NOCT: 800 W/m<sup>2</sup>, ambient temperature 20°C, AM 1.5

Operating parameters	
Maximum voltage	1500 V
Maximum series fuse rating, Ir	30 A
Power output tolerance	0 - +3%
Voc and Isc tolerance	±3%
Fire rating	Class A (UL 790)
Protection class	Class II (IEC 61140)
Mechanical loads	Front load 5400 Pa, Back load 2400 Pa

Corporate and product certificates	
ECOVADIS rating - Platinum medal (TOP 1%)	
Solar Industry Forced Labor Prevention Pledge by SEIA	
ISO9001:2015 - Quality Management Systems	
ISO14001:2015 - Environmental Management System	
WEEE compliance in Germany	
PV CYCLE Italy	
IEC 61215 - Terrestrial photovoltaic (PV) modules - Design qualification and type approval	
IEC 61730 - Photovoltaic (PV) module safety qualification	
IEC 61701 - Photovoltaic (PV) modules - Salt mist corrosion testing	
IEC 62716 - Photovoltaic (PV) modules - Ammonia corrosion testing	
IEC TS 62804 - Photovoltaic (PV) modules - Test methods for the detection of potential-induced degradation	
Hail resistance HW3/RG3	
Certificate of Factory Production Control (UK) - MCS	
Fire reaction class: 1 - LAPI	

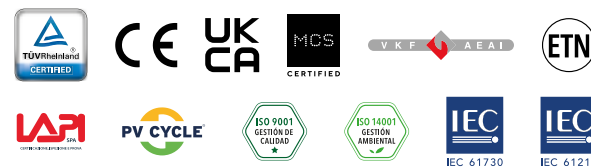

NOTE: Read the safety and installation manual before using the product. This data sheet is not legally binding, Eurener reserves the right of final interpretation. Eurener reserves the right to change the product characteristics and/or specifications without prior notice. The latest versions of all documents can always be found on our website at [www.eurener.com](http://www.eurener.com).

**SINCE 1997**  
 more than energy

**eurener.com**  
 contact@eurenerworld.com  
 +34 960 045 515  
 Calle Colón, 1-23  
 46004, Valencia, Spain

### European Experts in Residential modules

Since 1997 our main purpose has been to supply quality and long-lasting photovoltaic modules that allow us and future generations, to continue generating clean energy to take care of our planet.







## MEPV COLOURED Series

↳ *Solar panels that shine in every tones.*

Enhance your style with vibrant colours. Solar panels that blend seamlessly to give every surface a unique glow.

## COLOURED — TOPCON N-TYPE TECHNOLOGY

› *from 350 to 365W*



### TOPCon technology

It adds a thin oxide layer to the cell composition to further reduce recombination losses and increase the efficiency.



### Colour selection

Modules available in 3 colours for a perfect match with different roofs or facades.



### BIPV

Perfect module for architectural integration.



### High reliability

PID resistance, certified according to IEC TS 62804 standards.

Salt mist resistance, certified according to IEC 61701 standards.

Ammonia resistance, certified according to IEC 62716 standards.



### Hail resistance RG3/HW3

Certified resistance against hail impacts of 30 mm diameter at 23.9 m/s.



### Optimized area (<math><2m^2</math>)

Perfect size for comfortable installations and easy handling.

Maintaining suitable power outputs.





## MEPV Coloured Series

### DATA SHEETS

- › Eurener MEPV Coloured 350-360W  
*pag. 71/72*
- › Eurener MEPV Terracotta 350-365W  
*pag. 73/74*



European Experts  
in Residential Modules

## Coloured TOPCon N-type

# › 350 - 360W



### Module efficiency

Module efficiency up to 18.44 %



### Colour selection

Wide range of colours for perfect BIPV projects



### PID resistance

Certified according to IEC TS 62804 standards



### Increased resistance

Certified resistance against salt mist and ammonia



### Hail resistance

RG3/HW3 certified



### Easy to handle

Comfortable installation thanks to an optimized area size

# 20

Years

**Product Warranty**

+5 years for Premium Partners

# 30

Years

**Performance Warranty**

Linear Warranty

**2%** First year degradation

**0.55%** Annual degradation

**82.05%** Power in year 30

### Light up your world with Eurener

Eurener's extensive portfolio of certifications and awards is testament to our unwavering commitment to our partners and our deep sense of social and ethical responsibility.





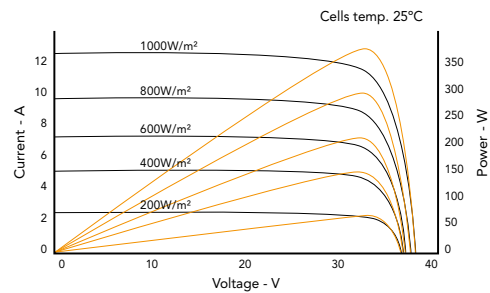
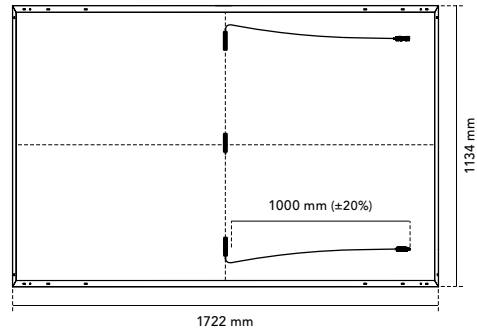

Mechanical Specification	
Solar cells	N-Type monocrystalline silicon cells
Front Glass	3.2 mm thick tempered glass with high strength and ARC
Frame	Terracotta/Emerald/Anthracite anodized aluminium
Junction Box	IP68, 3 by-pass diodes
Connector	Connector MC4 compatible
Cable	1000 mm (±20%) length and 4 mm <sup>2</sup> section
Dimension	1722 x 1134 x 30 mm (±1%)
Area	1.95 m <sup>2</sup>
Weight	20.5 kg
Packaging	936 pcs/truck

Temperature Coefficients	
Temperature coefficient of Isc (α)	0.05 %/°C
Temperature coefficient of Voc (β)	-0.28 %/°C
Temperature coefficient of Pmax (γ)	-0.29 %/°C
Temperature range	-40 °C ~ +85 °C
Nominal operating cell temperature (NOCT)	45 ± 2 °C

	TERRACOTTA		EMERALD		ANTHRACITE	
	MEPV 350	MEPV 360	MEPV 350	MEPV 360	MEPV 350	MEPV 360

Electrical Characteristics						
	STC					
Nominal power, Pmax	350 Wp	360 Wp	350 Wp	360 Wp	350 Wp	360 Wp
Short-circuit current (Isc)	11.92 A	12.24 A	11.93 A	12.25 A	11.92 A	12.23 A
Open-circuit voltage (Voc)	36.91 V	37.15 V	36.93 V	37.17 V	36.89 V	37.14 V
Maximum power current (Imp)	11.44 A	11.69 A	11.44 A	11.70 A	11.43 A	11.68 A
Maximum power voltage (Vmp)	30.65 V	30.85 V	30.66 V	30.86 V	30.65 V	30.86 V
Module efficiency	17.92 %	18.44 %	17.92 %	18.44 %	17.92 %	18.44 %

Electrical Characteristics						
	NOCT					
Nominal power, Pmax	265 Wp	270 Wp	265 Wp	270 Wp	265 Wp	270 Wp
Short-circuit current (Isc)	9.38 A	9.54 A	9.38 A	9.55 A	9.36 A	9.53 A
Open-circuit voltage (Voc)	34.90 V	35.17 V	34.93 V	35.20 V	34.89 V	35.15 V
Maximum power current (Imp)	9.23 A	9.36 A	9.24 A	9.36 A	9.22 A	9.35 A
Maximum power voltage (Vmp)	28.73 V	28.87 V	28.69 V	28.91 V	28.75 V	28.89 V

\* STC: 1000 W/m<sup>2</sup>, module temperature 25°C, AM 1.5 \* NOCT: 800 W/m<sup>2</sup>, ambient temperature 20°C, AM 1.5

Operating parameters	
Maximum voltage	1000 - 1500 V
Maximum series fuse rating, Ir	25 A
Power output tolerance	0 - +3%
Voc and Isc tolerance	±3%
Fire rating	Class C (UL 790)
Protection class	Class II (IEC 61140)
Mechanical loads	Front load 5400 Pa, Back load 2400 Pa

Corporate and product certificates	
ECOVADIS rating - Platinum medal (TOP 1%)	
Solar Industry Forced Labor Prevention Pledge by SEIA	
ISO9001:2015 - Quality Management Systems	
ISO14001:2015 - Environmental Management System	
WEEE compliance in Germany	
PV CYCLE Italy	
IEC 61215 - Terrestrial photovoltaic (PV) modules - Design qualification and type approval	
IEC 61730 - Photovoltaic (PV) module safety qualification	
IEC 61701 - Photovoltaic (PV) modules - Salt mist corrosion testing	
IEC 62716 - Photovoltaic (PV) modules - Ammonia corrosion testing	
IEC TS 62804 - Photovoltaic (PV) modules - Test methods for the detection of potential-induced degradation	
Hail resistance HW3/RG3	
Certificate of Factory Production Control (UK) - MCS	
Fire reaction class: 1 - LAPI	



NOTE: Read the safety and installation manual before using the product. This data sheet is not legally binding, Eurener reserves the right of final interpretation. Eurener reserves the right to change the product characteristics and/or specifications without prior notice. The latest versions of all documents can always be found on our website at [www.eurener.com](http://www.eurener.com).

**SINCE 1997**  
more than energy

**eurener.com**  
contact@eurenerworld.com  
+34 960 045 515  
Calle Colón, 1-23  
46004, Valencia, Spain

**European Experts in Residential modules**

Since 1997 our main purpose has been to supply quality and long-lasting photovoltaic modules that allow us and future generations, to continue generating clean energy to take care of our planet.

## Terracotta TOPCon N-type

# > 350 - 365W



- +18.7% Module efficiency**  
Module efficiency up to 18.71 %
- Colour RAL 8001**  
Perfect integration on demanding BIPV projects
- PID resistance**  
Certified according to IEC TS 62804 standards
- Increased resistance**  
Certified resistance against salt mist and ammonia
- Hail resistance**  
RG3/HW3 certified
- Easy to handle**  
Comfortable installation thanks to an optimized area size

**20 Years**  
Product Warranty  
+5 years for Premium Partners

**30 Years**  
Performance Warranty  
Linear Warranty

**2%** First year degradation  
**0.55%** Annual degradation  
**82.05%** Power in year 30

### Light up your world with Eurener

Eurener's extensive portfolio of certifications and awards is testament to our unwavering commitment to our partners and our deep sense of social and ethical responsibility.





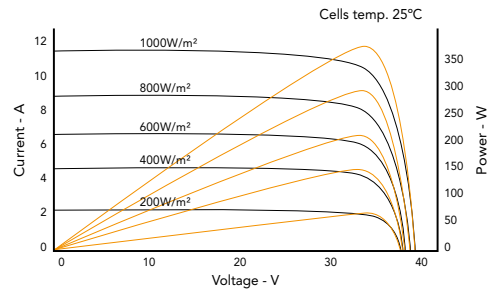
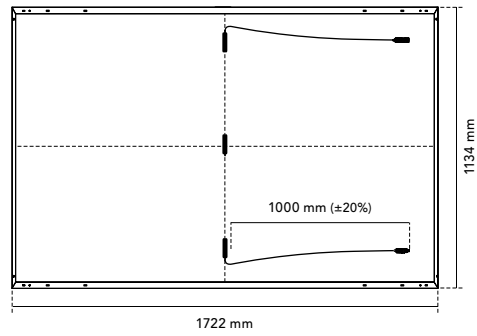

Mechanical Specification	
Solar cells	N-Type monocrystalline silicon cells
Front Glass	3.2 mm thick tempered glass with high strength and ARC
Frame	Terracotta anodized aluminium
Junction Box	IP68, 3 by-pass diodes
Connector	Connector MC4 compatible
Cable	1000 mm (±20%) length and 4 mm <sup>2</sup> section
Dimension	1722 x 1134 x 30 mm (±1%)
Area	1.95 m <sup>2</sup>
Weight	20.5 kg
Packaging	936 pcs/truck

Temperature Coefficients	
Temperature coefficient of Isc (α)	0.05 %/°C
Temperature coefficient of Voc (β)	-0.28 %/°C
Temperature coefficient of Pmax (γ)	-0.29 %/°C
Temperature range	-40 °C ~ +85 °C
Nominal operating cell temperature (NOCT)	45 ± 2 °C

	MEPV 350	MEPV 355	MEPV 360	MEPV 365
<b>Electrical Characteristics</b>				
STC				
Nominal power. Pmax	350 Wp	355 Wp	360 Wp	365 Wp
Short-circuit current (Isc)	11.43 A	11.47 A	11.61 A	11.69 A
Open-circuit voltage (Voc)	38.47 V	38.59 V	39.98 V	39.22 V
Maximum power current (Imp)	10.52 A	10.62 A	10.71 A	10.83 A
Maximum power voltage (Vmp)	33.26 V	33.42 V	33.63 V	33.69 V
Module efficiency	17.95 %	18.23 %	18.45 %	18.71 %
<b>Electrical Characteristics</b>				
NOCT				
Nominal power. Pmax	266 Wp	270 Wp	274 Wp	277 Wp
Short-circuit current (Isc)	8.99 A	9.06 A	9.17 A	9.19 A
Open-circuit voltage (Voc)	36.24 V	36.43 V	36.56 V	36.87 V
Maximum power current (Imp)	8.55 A	8.59 A	8.69 A	8.75 A
Maximum power voltage (Vmp)	31.12 V	31.40 V	31.49 V	31.69 V

\* STC: 1000 W/m<sup>2</sup>, module temperature 25°C, AM 1.5  
 \* NOCT: 800 W/m<sup>2</sup>, ambient temperature 20°C, AM 1.5

Operating parameters	
Maximum voltage	1000 - 1500 V
Maximum series fuse rating. Ir	25 A
Power output tolerance	0 - +3%
Voc and Isc tolerance	±3%
Fire rating	Class C (UL 790)
Protection class	Class II (IEC 61140)
Mechanical loads	Front load 5400 Pa, Back load 2400 Pa

Corporate and product certificates	
ECOVADIS rating - Platinum medal (TOP 1%)	
Solar Industry Forced Labor Prevention Pledge by SEIA	
ISO9001:2015 - Quality Management Systems	
ISO14001:2015 - Environmental Management System	
WEEE compliance in Germany	
PV CYCLE Italy	
IEC 61215 - Terrestrial photovoltaic (PV) modules - Design qualification and type approval	
IEC 61730 - Photovoltaic (PV) module safety qualification	
IEC 61701 - Photovoltaic (PV) modules - Salt mist corrosion testing	
IEC 62716 - Photovoltaic (PV) modules - Ammonia corrosion testing	
IEC TS 62804 - Photovoltaic (PV) modules - Test methods for the detection of potential-induced degradation	
Hail resistance HW3/RG3	
Certificate of Factory Production Control (UK) - MCS	
Fire reaction class: 1 - LAPI	



NOTE: Read the safety and installation manual before using the product. This data sheet is not legally binding, Eurener reserves the right of final interpretation. Eurener reserves the right to change the product characteristics and/or specifications without prior notice. The latest versions of all documents can always be found on our website at [www.eurener.com](http://www.eurener.com).

**SINCE 1997**  
 more than energy

**eurener.com**  
 contact@eurenerworld.com  
 +34 960 045 515  
 Calle Colón, 1-23  
 46004, Valencia, Spain

**European Experts in Residential modules**

Since 1997 our main purpose has been to supply quality and long-lasting photovoltaic modules that allow us and future generations, to continue generating clean energy to take care of our planet.







Motala, SWEDEN  
Solar for residential development





**eurener**  
energía solar

MORE THAN ENERGY  
[www.eurener.com](http://www.eurener.com)